

### Hydraulic Symbol

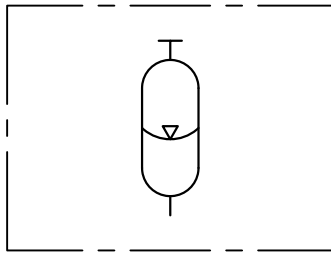

### Specifications

<b>Material of Construction</b>	
Body	: Carbon Steel / Stainless Steel.
Bladder	: Nitrile(NBR) / Butyl (IIR) / Viton (FKM) / EPDM .... others listed on ordering code.
<b>Connections</b>	
Gas Side	: 5/8" UNF / 1/4" BSP / 5/16" UNEF/Vg8 / 7/8" UNF. Others on request.
Fluid Side	: Female Threaded or Flanged. Others on request.
Paint-CS Accumulators	: Externally painted in RAL-5010. Others on request.

### Technical Data

Design	: Seamless / Fabricated shell.
Max. Pressure (PS)	: 16-360 Bar.
Test Pressure (PT)	: 1.43 x PS
Temperature range	: -20°C to +80°C (Standard)
Allowable pre.ratio ( $P_2/P_0$ )	: 4:1
Nominal capacity	: 0.2 to 575 Ltrs.
Max. Flow rates	: Refer page 6.
<b>Fluid</b>	
Fluid Viscosity range	: 10 to 400 cSt
Recommended viscosity	: 32 cSt
Fluid contamination degree:	Class 21/19/16 according to ISO 4406:1999 or better on request.

### Description

A hydro-pneumatic accumulator is a device used specifically for storage of liquid under pressure. As liquids, for all practical purposes, are incompressible, this objective is achieved by utilizing the compressibility of gases.

A flexible rubber separator i.e., bladder is fitted into the accumulator shell.

An inert gas - nitrogen - is filled into the bladder through a pressure valve to a pressure  $P_0$ . The bladder expands, filling the entire volume  $V_0$  of the accumulator shell.

When the system pressure  $P_1$  is higher than the gas precharge pressure  $P_0$ , the liquid enters the accumulator and the bladder is compressed reducing the gas volume to  $V_1$ .

Should the liquid pressure rise to  $P_2$ , the volume of gas reduces to  $V_2$  with an attendant rise in pressure, thus balancing the Liquid pressure.

A potential energy is now stored in the accumulator to be utilised whenever needed.

### Certification

The EPE bladder accumulators are generally designed & manufactured according to European directive. They can also be supplied as per ASME or others on request.

### Materials

In standard version, the shell is made of carbon steel and painted on the outside with a coat of rust inhibitor; the valves are made from carbon steel - phosphated. This configuration is suitable for oils and non-corrosive liquids.

Options for shell in stainless steel / aluminium / titanium alloy are available on request.

Shells Nickle plated / Rilsan coated or others are also available on request.

## Operation

Sequence of operations in the accumulator working cycle

- A) General appearance in assembled condition.
- B) Bladder occupying the entire space inside the shell after precharge.
- C&D) The accumulator in working condition between minimum pressure (C) & maximum pressure (D) delivers fluid and calculated between  $V_1$  &  $V_2$  i.e.,  $\Delta V = V_1 - V_2$ .

Accumulator now has a potential energy to be utilised as desired.

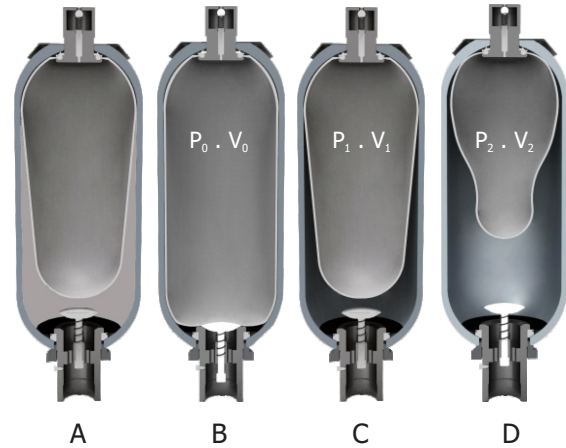

Fig.1

## Construction

The EPE bladder accumulator, generally designed & manufactured according to European directive, comprises a steel shell in which is fitted a bladder complete with a gas valve and a fluid port with the poppet valve (Fig.2)

**The accumulator shell** is a pressure vessel forged or fabricated from high grade steel designed and manufactured to meet relevant international standards. For special applications various surface coatings are available as well as stainless steel construction.

**The bladder** construction which is unique to EPE is moulded in a single piece thus obviating problems associated with seamed construction. The gas valve is fitted in such a manner which allows it to be connected and easily and safely. In addition the valve, not an integral part of the bladder, can be re-used, thus reducing maintenance costs.

Bladders are normally manufactured from nitrile, but for special applications butyl, neoprene, ethylene-propylene etc, are available.

**The gas valve** is connected to the bladder by a rubber coated washer to ensure a gas tight joint and a non return valve is incorporated for bladder inflation. The bladder, complete with the gas valve is attached to the accumulator shell by a lock nut, and the assembly is protected by a cover.

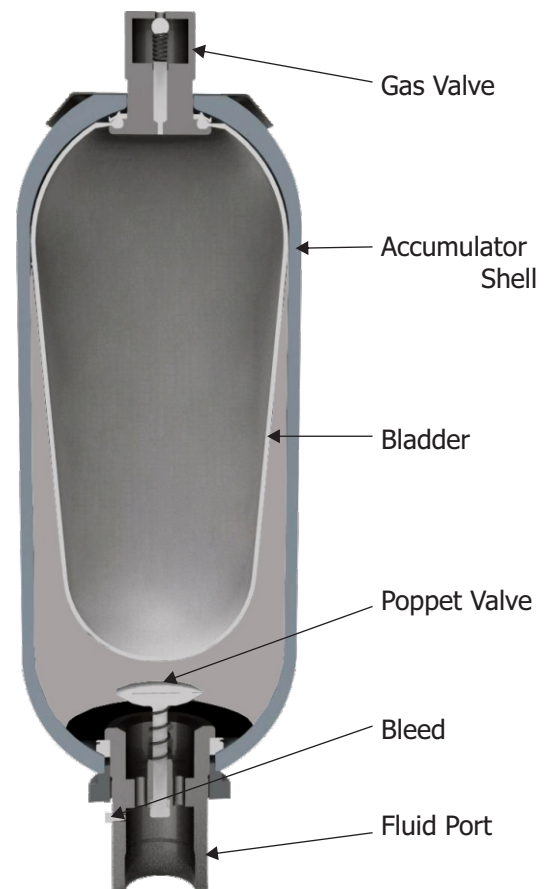

Fig.2

Standard accumulators (types - AS / ASHF / ASWP) are installed with a **poppet valve** to prevent bladder from extruding out of the fluid port while allowing fluid to flow. In low-pressure range (type-ASWD/ASLV/ASLVHF) the **anti-extrusion valve** is installed.

## Material

The choice of the elastomer used for the bladder depends on the liquid to be used and on the operating temperatures (and at times, storage). In the chart below, each polymer has a designated letter to be used in the ordering code.

Code letter	Polymer	ISO	Temperature range (°C)	Some of the liquids compatible with the polymer
P	Nitrile (Buna-N / Perbunan)	NBR	-20 to +85	Mineral, vegetable, silicon and lubricating oils, industrial water, glycols, non-flammable liquids (HFA-HFB-HFC), aliphatic hydrocarbons, butane, diesel oil, kerosene, fuel oils etc.
F	Low Temperature Nitrile	NBR	-40 to +70	The same as with standard nitrile + a number of different types of Freon. (This contains less acrylonitrile than the standard and is therefore more suitable for low temperatures, but its chemical resistance is slightly lower.)
H	Nitrile for Hydrocarbons	NBR	-10 to +90	The same as with standard nitrile + regular and premium grade slightly aromatic gasoline.
K	Hydrogenated Nitrile	HNBR	-50 to +130	The same as with standard nitrile but with excellent performance at both high and low temperatures.
A	For food-stuffs	NBR	-20 to +85	Foods (specify which type when ordering).
B	Butyl	IIR	-20 to +90	Phosphoric esters (HFD-R), phosphate esters, fyrquel, hot water, ammonia, caustic soda, some kinds of Freon (22-31-502), glycol-based brake fluids, some acids, alcohols, ketones, esters, skydrol 7000, etc.
E	Ethylene-Propylene	EPDM	-20 to +90	Break fluids, hot water, leaching fluids, detergents, water-glycol (HFC), many acids and bases, saline solutions, skydrol 500, etc.
N	Chloroprene (Neoprene)	CR	-20 to +85	Freon (12-21-22-113-114-115), water and aqueous solutions, ammonia, carbon dioxide, mineral, paraffin and silicon oils.
Y	Epichloridrin	ECO	-30 to +100	Lead-free gasoline, mineral oils.
V	Viton (Fluoroelastomer)	FKM	-20 to +121	The same as with standard nitrile but with excellent performance at both high and low temperatures.

\* Check availability before ordering.

## Durability of the Bladders

It is essential, in order to make the correct choice, to take into consideration the working conditions that the bladder will be operating in, because these can considerably affect the durability of the bladder. Assuming that the liquid used is **clean** and compatible with the bladder material, there are a number of factors which can affect the life of the bladder:

**The precharge pressure  $P_0$**  - In most cases the values recommended in Gas Precharge Pressure - page-3 are valid although, as the pressure and, above all, the velocity of the yield required increase, there is the danger that in each cycle the bladder will knock against the poppet valve. In these cases it is possible to use  $P_0 = 0.8$  to  $0.7 P_1$ .

**The  $P_2/P_0$  ratio** - Any increase in this, will increase the stress the bladder is subjected to in each cycle.

**The maximum operating pressure  $P_2$**  - Any increase in this will subject the bladder to greater stress.

**Flow rate** - Flow rate does not affect bladder working life if values given in Table.2 are not exceeded. When approaching the maximum values, make sure there remains a residual volume of liquid > 10% of the volume  $V_0$  in the accumulator, in both loading & unloading conditions.

**The frequency** or number of cycles per day.

**Installation** - The vertical position with gas valve on top is the recommended arrangement. When the position is horizontal the bladder tends to rest and rub against the accumulator body. This could result in quicker wear.

**The operating temperature** - This is one of the factors which most affects the life of the bladder: at very low temperatures the bladder tends to become brittle; as the temperature rises, reaching, or going beyond the limits for the elastomer, the stress the bladder is subjected to increases exponentially, which can lead to fracturing within a short time.

It should be remembered that the temperature in the accumulator is in many cases higher than the one of the system, and that it rises with each increase of  $P_2$ , of  $P_2/P_1$ , and with the volume of the accumulator (in other words, larger the accumulator, lesser is the capacity to dissipate heat).

# Ordering Code - Accumulators

1	2	3	4	5	6	7	8	9	10	11	12	13	14
AS	35	P	360	C	G	09	F	0	C	C	V	/ PO:10 /	- - -

↑ To indicate only if applicable ↓

1	<b>Series</b>	Standard Accumulator - Seamless Shell High-Flow Accumulator - Seamless Shell Welded Accumulator - Poppet Design Welded Accumulator - Disc Design Large Volume Accumulator High Flow Large Volume Accumulator Liquid Separator Accumulator Transfert Accumulator	= AS = ASHF = ASWP = ASWD (P0 ≤ 15 bar) = ASLV = ASLVHF = ASL = AST
2	<b>Nominal Capacity (Ltrs)</b>	MWP - 330 Bar (AS) MWP - 350 Bar (AS) MWP - 360 Bar (AS) MWP - 330 Bar (AS) MWP - 330 Bar (ASHF) MWP - 30~165 Bar (ASWP) MWP - 30~70 Bar (ASWD) MWP - 16/35 Bar (ASLV / ASLVHF)	= 0.2 = 0.7 = 1-55 = 60-130 = 10-55 = 3-55 = 1.5-55 = 100-575
3	<b>Bladder &amp; Seal material</b>	Nitrile (NBR) Butyl (IIR) Viton (FKM) Ethylene-Propylene (EPDM) Hydrogenated Nitrile (HNBR) Neoprene (CR) Nitrile for Hydrocarbons Low Temp. Nitrile Epichlorohydrin (ECO) For Food	= P (standard) = B = V = E = K = N = H = F = Y = A
4	<b>Max working pressure (Bar)</b>	For 0.2 (AS) For 0.7 (AS) For 1-55 (AS) For 60-130 (AS) For 10-55 (ASHF) For 3-55 (ASWP) For 1.5-5 (ASWD) For 10-55 (ASWD) For 100-575 (ASLV / ASLVHF)	= 330 = 350 = 360 = 330 = 330 = 30 / 50 / 70 120 / 165 = 70 = 30 = 16 / 35
5	<b>Shell material</b>	Carbon Steel Nickel Coated Carbon Steel Stainless Steel Rilsan Coated Carbon Steel	= C (standard) = N = X = V

\* Before ordering, check for availability

# Ordering Code - Accumulators

1	2	3	4	5	6	7	8	9	10	11	12	13	14
AS	35	P	360	C	G	09	F	0	C	C	V	/ PO:10 /	- - -

↑ To indicate only if applicable ↑

6	<b>Fluid Port Connection type</b>	BSPP (Parallel Thread) BSPT (Taper Thread) NPT (Taper Thread) To suit SAE 3000 PSI flange To suit SAE 6000 PSI flange Square Flange SAE Internal Thread Metric UNI-DIN Flange ANSI Flange Adaptor (for use with type G connection)	= <b>G</b> (standard) = <b>T</b> = <b>N</b> = <b>3</b> = <b>6</b> = <b>Q</b> = <b>S</b> = <b>M</b> = <b>D</b> = <b>A</b> = <b>R#</b> {# = G/T/N/S/M}
---	-----------------------------------	--	--

7	<b>Fluid Port Connection size</b>	for <b>G</b> 1/8"      = <b>01</b> <b>T</b> 1/4"      = <b>02</b> <b>N</b> 3/8"      = <b>03</b> <b>3</b> 1/2"      = <b>04</b> <b>6</b> 3/4"      = <b>05</b> <b>Q</b> 1"        = <b>06</b> <b>R</b> 1-1/4"    = <b>07</b> 1-1/2"    = <b>08</b> 2"        = <b>09</b> 2-1/2"    = <b>10</b> 3"        = <b>11</b> 3-1/2"    = <b>12</b> 4"        = <b>13</b> Multi Ports (R) = <b>zz</b> <small>(Ref. other variants)</small>	for <b>D</b> DN20/40    = <b>51</b> DN20/250   = <b>52</b> DN25/16    = <b>53</b> DN25/40    = <b>54</b> DN25/250   = <b>55</b> DN32/40    = <b>56</b> DN32/250   = <b>57</b> DN40/40    = <b>58</b> DN40/250   = <b>59</b> DN50/16    = <b>60</b> DN50/40    = <b>61</b> DN50/64    = <b>62</b> DN50/250   = <b>63</b> DN65/16    = <b>64</b> DN65/40    = <b>65</b> DN80/16    = <b>66</b> DN100/16   = <b>67</b> DN100/40   = <b>68</b>	for <b>A</b> 3/4" /300    = <b>81</b> 3/4" /1500   = <b>82</b> 1" /300      = <b>83</b> 1" /1500     = <b>84</b> 1-1/4" /300   = <b>85</b> 1-1/4" /1500 = <b>86</b> 1-1/2" /300   = <b>87</b> 1-1/2" /1500 = <b>88</b> 2" /150      = <b>89</b> 2" /300      = <b>90</b> 2" /400      = <b>91</b> 2" /1500     = <b>92</b> 2-1/2" /150   = <b>93</b> 2-1/2" /300   = <b>94</b> 2-1/2" /400   = <b>95</b> 2-1/2" /1500 = <b>96</b> 4" /150      = <b>97</b> 4" /300      = <b>98</b>
---	-----------------------------------	---	---	--

8	<b>Fluid Port Connection design</b>	Female Thread      = <b>F</b> Male Thread        = <b>M</b> For SAE Flange     = <b>S</b> Flange                = <b>L</b> Socket Weld Nipple = <b>SW</b>	for <b>A</b> WN-RF        = <b>WN</b> WN-RTJ      = <b>WJ</b> SO-RF        = <b>SO</b> SW-RF        = <b>SW</b> SW-RTJ      = <b>SJ</b>
---	-------------------------------------	---	---

\* Before ordering, check for availability

# Ordering Code - Accumulators

1	2	3	4	5	6	7	8	9	10	11	12	13	14
<b>AS</b>	<b>35</b>	<b>P</b>	<b>360</b>	<b>C</b>	<b>G</b>	<b>09</b>	<b>F</b>	<b>0</b>	<b>C</b>	<b>C</b>	<b>V</b>	<b>PO:10</b>	- - -

↑ To indicate only if applicable ↑

9	<b>Test Certification</b>	Factory Testing CE/PED SELO / ML (China) ASME Sec.VIII Divn.1 App.22 (w/o stamp) ASME Sec.VIII Divn.1 App.22 - U stamp Others / Dual Certification - on request	= 0 = 8 = 3 = 7W = 7U
10	<b>Fluid Valve material</b>	Carbon steel Nickel Coated carbon steel Stainless Steel Zn-Ni Coated Carbon Steel	= C (standard) = N = X = Z
11	<b>Gas Valve material</b>	Carbon steel Nickel Coated carbon steel Stainless Steel Zn-Ni Coated Carbon Steel	= C (standard) = N = X = Z
12	<b>Gas Fill Valve connection</b>	Standard - 5/8" UNF 5/8" UNF in Stainless Steel Without Gas Fill Valve 5/16" UNEF/Vg8 1/4" BSP M16x2.0 5/16" UNEF (7/8 UNF Gas Fill Valve Body) Double Lock Military Valve 7/8" UNF (Integral in 7/8 UNF Gas Valve) M28x1.5	= V (standard) = X = 0 = 1 = 2 = 3 = 4 = 8 = 9 = M
13	<b>Precharge Pressure</b>	Uncharged Condition Precharge Pressure in bar	= - = XX
14	<b>Other Variants</b>	Refer page 7	= -

\* Before ordering, check for availability

# Ordering Code - Accumulators

1	2	3	4	5	6	7	8	9	10	11	12	13	14
AS	35	P	360	C	G	09	F	0	C	C	V	/ PO:10 /	- - -

↑ To indicate only if applicable ↑

14	<b>Other variants</b>	<p><u>Standard Accumulator - Without any variants</u></p> <p><b>Liquid Side Variants</b></p> <p>Liquid Adapter in SS (if different from FPA) = <b>L01</b>                      Poppet &amp; spring in SS (if different from FPA) = <b>L02</b>                      Fluid Port Assembly without Bleed Port = <b>L03</b>                      3-Way adaptor - 1/2" BSPF x 1/4" BSPF = <b>L11</b>                      3-Way adaptor - 1/2" BSPF x 3/8" BSPF = <b>L12</b>                      3-Way adaptor - 1/2" BSPF x 1/2" BSPF = <b>L13</b>                      3-Way adaptor - 3/4" BSPF x 1/4" BSPF = <b>L14</b>                      3-Way adaptor - 3/4" BSPF x 3/8" BSPF = <b>L15</b>                      3-Way adaptor - 1" BSPF x 1/4" BSPF = <b>L16</b>                      3-Way adaptor - 3/4" NPTF x 1/4" NPTF = <b>L17</b></p> <p><b>Gas Side Variants</b></p> <p>Protection cap in SS (if different from GVA) = <b>G01</b>                      Protection cap with Plastic Insert = <b>G02</b>                      Name plate in Brass = <b>G03</b>                      Name Plate in SS = <b>G04</b>                      7/8" UNF Gas Valve Body = <b>G05</b>                      M50x1.5 with 7/8" UNF Gas Valve Body = <b>G06</b>                      Lifting Hook = <b>G07</b>                      Adapter for connecting 1/4" Gauge (without gauge) = <b>G11</b>                      Adapter with xxx bar 63mm Pressure Gauge = <b>G12(xxx)</b>                      Adapter with xxx bar rupture disc = <b>G13(xxx)</b>                      Adapter with xxx bar rupture disc + 1/4" BSPF Port = <b>G14(xxx)</b>                      Adapter with xxx bar rupture disc + yyy bar 63mm Gauge = <b>G15(xxx/yyy)</b>                      Adapter with xxx bar rupture disc + 1/4" NPTF Port = <b>G16(xxx)</b>                      Adapter with xxx bar rupture disc + 3/8" NPTF Port = <b>G17(xxx)</b>                      Adapter with xxx bar rupture disc + 1/2" NPTF Port = <b>G18(xxx)</b>                      Adapter with VS214 Gas Safety Valve set at xxx bar = <b>G19(xxx)</b>                      Adapter with VS224X Gas Safety Valve set at xxx bar = <b>G20(xxx)</b>                      Adapter with 1/4" BSP Needle Valve = <b>G21</b>                      Adapter with 1/4" BSP Needle Valve in SS = <b>G22</b>                      Adapter with PGSV (Pressure Gauge Shut-off Valve) = <b>G23</b>                      Adapter with PGSV + xxx bar 63mm pressure gauge = <b>G24(xxx)</b></p> <p><b>External Variants</b></p> <p>Finish Paint - RAL-5003 = <b>E01</b></p> <p><b>Internal Variants</b></p> <p>Flushing to NAS-10 = <b>F10</b>                      Flushing to NAS-9 = <b>F09</b>                      Flushing to NAS-8 = <b>F08</b>                      Flushing to NAS-7 = <b>F07</b>                      Flushing to NAS-6 = <b>F06</b>                      Flushing to NAS-5 = <b>F05</b></p> <p><b>Other special requirements</b> = <b>SPL</b></p>	
----	-----------------------	---	--

\* Before ordering, check for availability

## Max. Flow Rates (l/min)

Type ↓ \ Size ⇒	0.2	0.7 to 1.5	3 to 6	10 to 55	60 to 130	100 to 575
AS / ASWP	160	300	600	1000	1800	-
ASHF	-	-	-	1800	-	-
ASWD	-	100	150	300	-	-
ASLV	-	-	-	-	-	900
ASLVHF	-	-	-	-	-	1200



# Dimensions - AS/ASHF/ASWP (Poppet design)

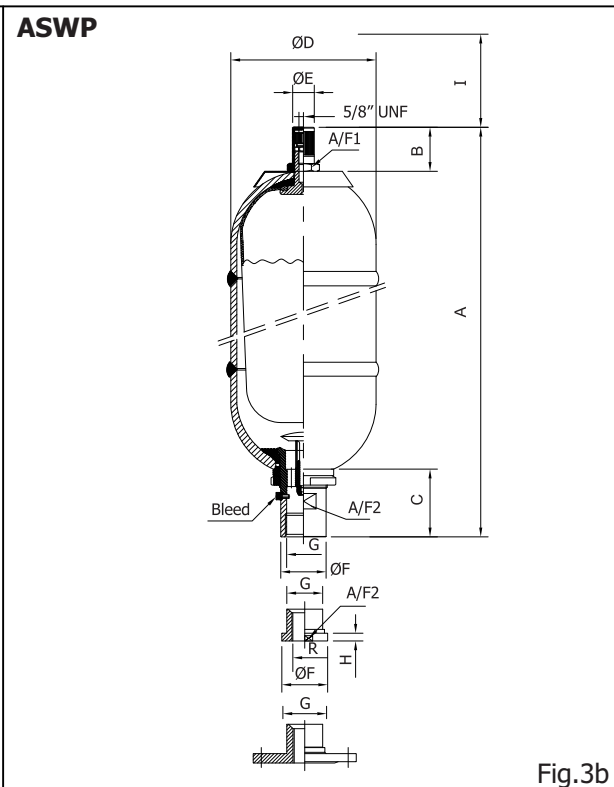
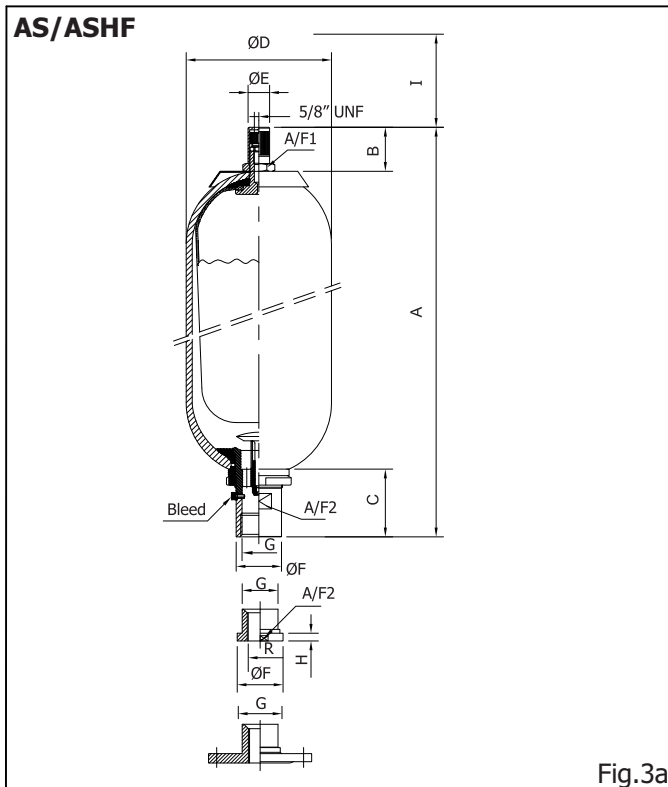

## Dimensions

Model	Max. Pre. bar	Gas Vol. ltrs	Dry Wt. kgs	Fluid Port Connection (BSP)		A	B	C	ØD	ØE	ØF	H	I	A/F1	A/F2
				G	R										
AS 0.2	330	0.2	1.6	1/2"	----	250	22	40	51	20	26	---	140	24	23
AS 0.7	360	0.7	2.2	3/4"	3/8"	280	47	52	90	25	36	---	140	24	23
AS 1		300													
AS 1.5		355													
AS 3		3	9	1-1/4"	3/8" - 1/2" - 3/4"	540	65	114	168	77	53	11	140	32	50
AS 4		4	12												
AS 5		5	14												
AS 6		6	16.5												
AS 10		10	26.5	2"	1/2" - 3/4" - 1" - 1-1/4" - 1-1/2"	570	60	101	223	55	77	11	140	70	70
AS 12		12	30.5												
AS 15		15	36.5												
AS 20	20	44													
AS 25	24	51.5													
AS 28	28	58.5													
AS 35	32	73.5													
AS 55	50	102	2-1/2"	1" - 1-1/2" - 2"	1915	60	137	356	55	97	11	140	90	90	
AS 60	60	135													
AS 80	80	169													
AS 100	100	203													
AS 130	130	233													
ASHF 10	330/ 360	10	33	2-1/2"	1" - 1-1/2" - 2"	620	60	137	226	55	97	11	140	90	90
ASHF 15		15	37												
ASHF 20		20	56												
ASHF 25		24	66												
ASHF 35		32	94												
ASHF 55		50	132												
ASWP 3	30/ 48/ 70/ 120/ 165	3	*	1-1/4"	3/8" - 1/2" - 3/4"	540	47	52	*	25	36	*	140	32	50
ASWP 4		4	*												
ASWP 5		5	*												
ASWP 6		6	*												
ASWP 10		10	*	2"	1/2" - 3/4" - 1" - 1-1/4" - 1-1/2"	570	60	101	*	55	97	*	140	70	70
ASWP 15		15	*												
ASWP 20		20	*												
ASWP 25		25	*												
ASWP 28		28	*												
ASWP 35		35	*												
ASWP 55	55	*													

\* Depends on the pressure and design standards

All dimensions in mm



# Spare Parts List - AS/ASHF/ASWP (Poppet design)

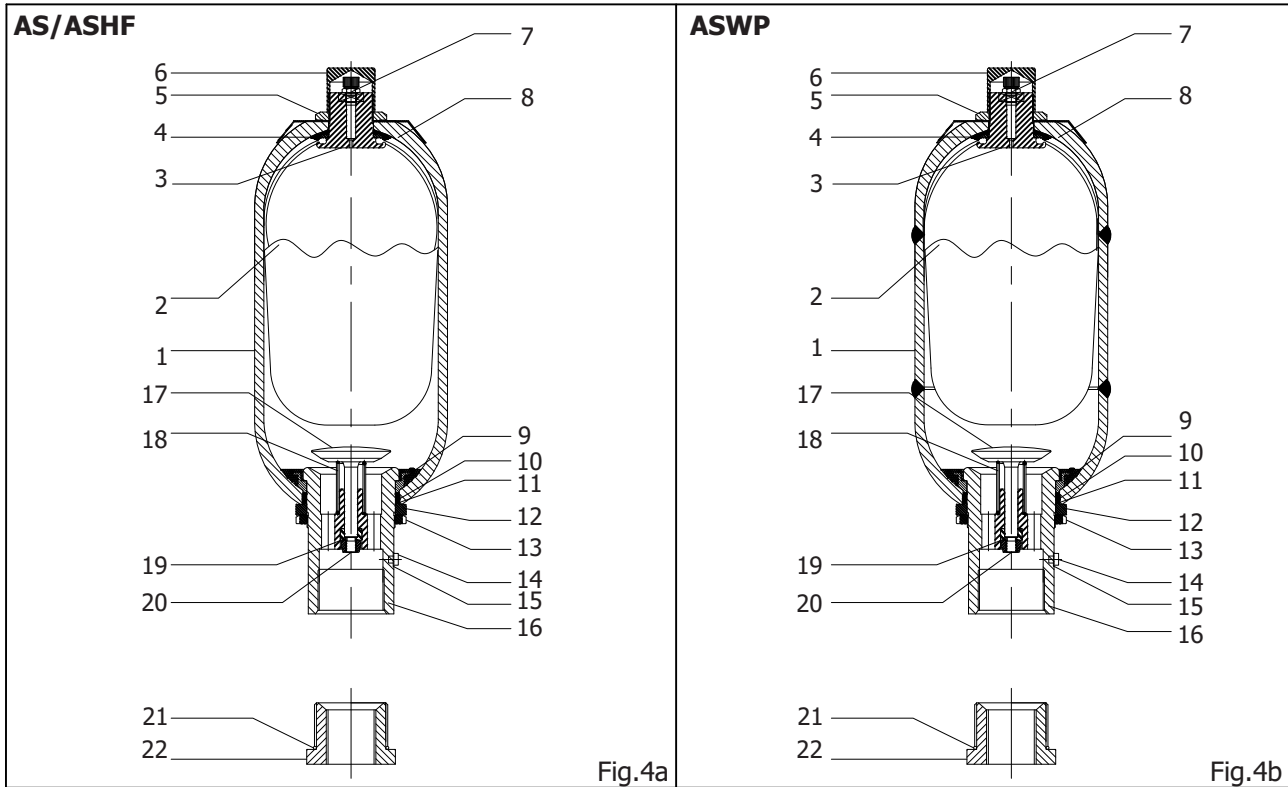

## Part Number \*

Item #	Description	Qty.	AS 0.2	AS 0.7	AS 1~1.5	AS 3 ASWP 3	AS 4~6 ASWP 4~6	AS 10~55 ASWP 10~55	AS 60~130 ASHF 10~55
1	Accumulator Shell	1	-	-	-	-	-	-	-
2	Bladder	1	-	-	-	-	-	-	-
3	Gas Valve Body	1	B10024	B10107	B10107	B10107	B10202	B10333	B10333
4	Rubber-coated Washer	1	C10024	C10104	C10106	C10106	C10205	C10334	C10334
5	Gas Valve Lock Nut	1	E10023	E10109	E10109	E10109	E10109	E10302	E10302
6	Protection Cap	1	PCAPFM	F10103	F10103	F10103	F10103	F10301	F10301
7	Gas Fill Valve	1	-	ASSY17	ASSY17	ASSY17	ASSY17	ASSY17	ASSY17
8	Name Plate	1	-	G10304	G10304	G10304	G10305	G10306	G10306
9	Retaining Ring	1	I10035	I10123	I10127	I10146	I10222	I10317	I10406
10	"O" Ring	1	I15022	I56022	I56022	211026	211030	237032	252030
11	Supporting Ring	1	K10038	K10133	K10133	K10150	K10227	K10320	I10405
12	Spacer Ring	1	L10037	L10120	L10120	L10145	L10223	L10319	I10404
13	Fluid Port Ring Nut	1	M10039	M10122	M10122	M10217	M10217	M10321	I10402
14	Bleed Screw	1	-	05XXXX	05XXXX	05XXXX	05XXXX	BBXXXX	BBXXXX
15	Seal Ring	1	-	C13384	C13384	C13384	C13384	C39XXX	C39XXX
16	Fluid Port Body	1	N10031	N10115	N10115	N10144	N10144	N10311	I10401
17	Poppet	1	O10028	O10111	O10111	O10221	O10221	O10310	I10408
18	Spring	1	P10029	P10112	P10112	P10149	P10149	P10322	I10409
19	Brake Bushing	1	-	Q10113	Q10113	Q10226	Q10226	Q10314	I10410
20	Self-Locking Nut	1	S10030	S10114	803XXX	S10228	S10228	S10341	807XXX
21	Adaptor O-Ring	1	-	097013	097009	161013	161013	212013	226035
22	Adaptor	1	-	-	-	-	-	-	-
Gas Valve Assembly - consists item # 3 to 7		1	A12002	A12021	A12022	A12022	A12042	A12062	A12062
Fluid Port Assembly - consists item # 9 to 20		1	H12004	H12023	H12024	H12025	H12044	H12064	I12401
Gasket Set - consists item # 9,10,11, 15		1	R12010	R12030	R12030	R12031	R12050	R12080	I12405

\* For Carbon Steel & Nitrile components

# Dimensions - ASWD/ASLV/ASLVHF (Disc design)

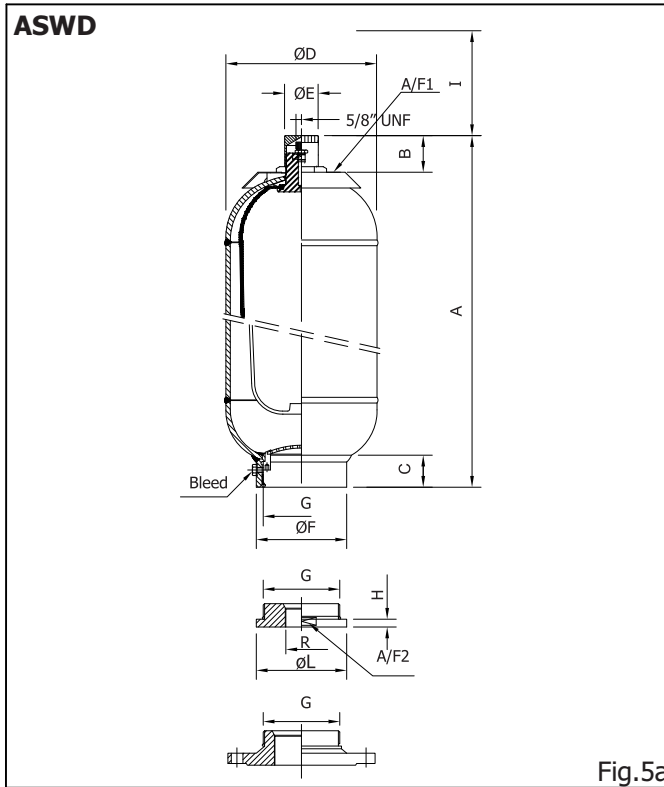

Fig.5a

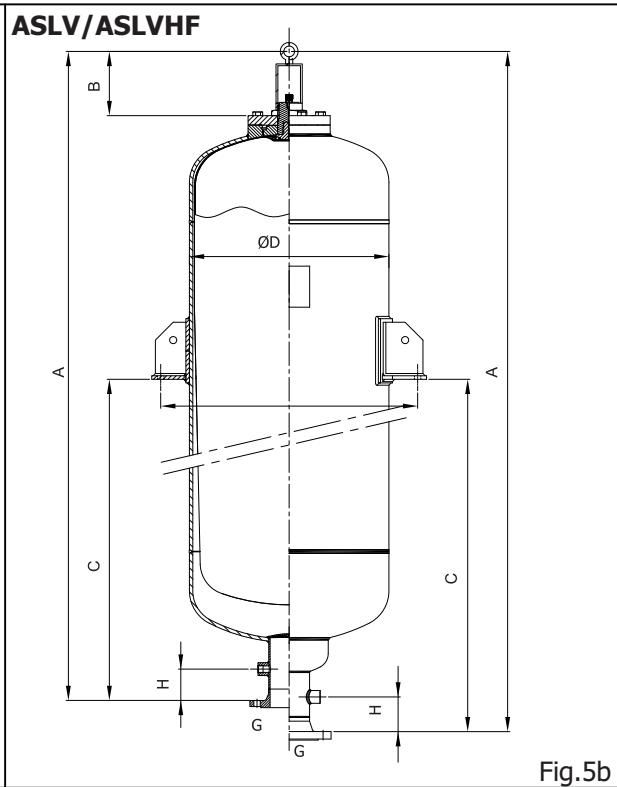

Fig.5b

## Dimensions

Model	Max. Pre. bar	Gas Vol. ltrs	Dry Wt. kgs	Fluid Port Conn.		A	B	C	ØD	ØE	ØF	H	I	ØL	A/F1	A/F2			
				G BSP	R BSP														
ASWD 1.5	70	1.5	*	2"	3/4" . 1"	290	47	48	114	25	72	11	140	74	32	70			
ASWD 3		3	*		1-1/4"	460													
ASWD 4		4	*	2-1/2"	1" . 1-1/4"	355											168	88	88
ASWD 5		5	*		1-1/2"	412													
ASWD 10	30	10	*	4"	2" . 3"	470	60	50	219	55	130	14	140	130	70	120			
ASWD 15		15	*			610													
ASWD 20		20	*			750													
ASWD 25		25	*			895													
ASWD 28		28	*			1025													
ASWD 35		35	*			1325													
ASWD 55		550	*			1850													
ASLV 100	16/35	100	*	DN-100	-	897	180	346	559	--	--	56	---	--	--	--			
ASLV 150		150	*			1132											441		
ASLV 200		200	*			1347											639		
ASLV 275		275	*			1688											845		
ASLV 300		300	*			1787											868		
ASLV 375		375	*			2112											1011		
ASLV 475		475	*			2552											1245		
ASLV 530		530	*			2805											1378		
ASLV 575		575	*			2987											1473		
ASLVHF 100		16/35	100			*											DN-100	-	987
ASLVHF 150	150		*	1222	531														
ASLVHF 200	200		*	1437	729														
ASLVHF 275	275		*	1778	935														
ASLVHF 300	300		*	1877	958														
ASLVHF 375	375		*	2202	1101														
ASLVHF 475	475		*	2642	1335														
ASLVHF 530	530		*	2895	1468														
ASLVHF 575	575		*	3077	1563														

\* Depends on the pressure and design standards

All dimensions in mm

# Spare Parts List - ASWP/ASLV/ASLVHF (Disc design)

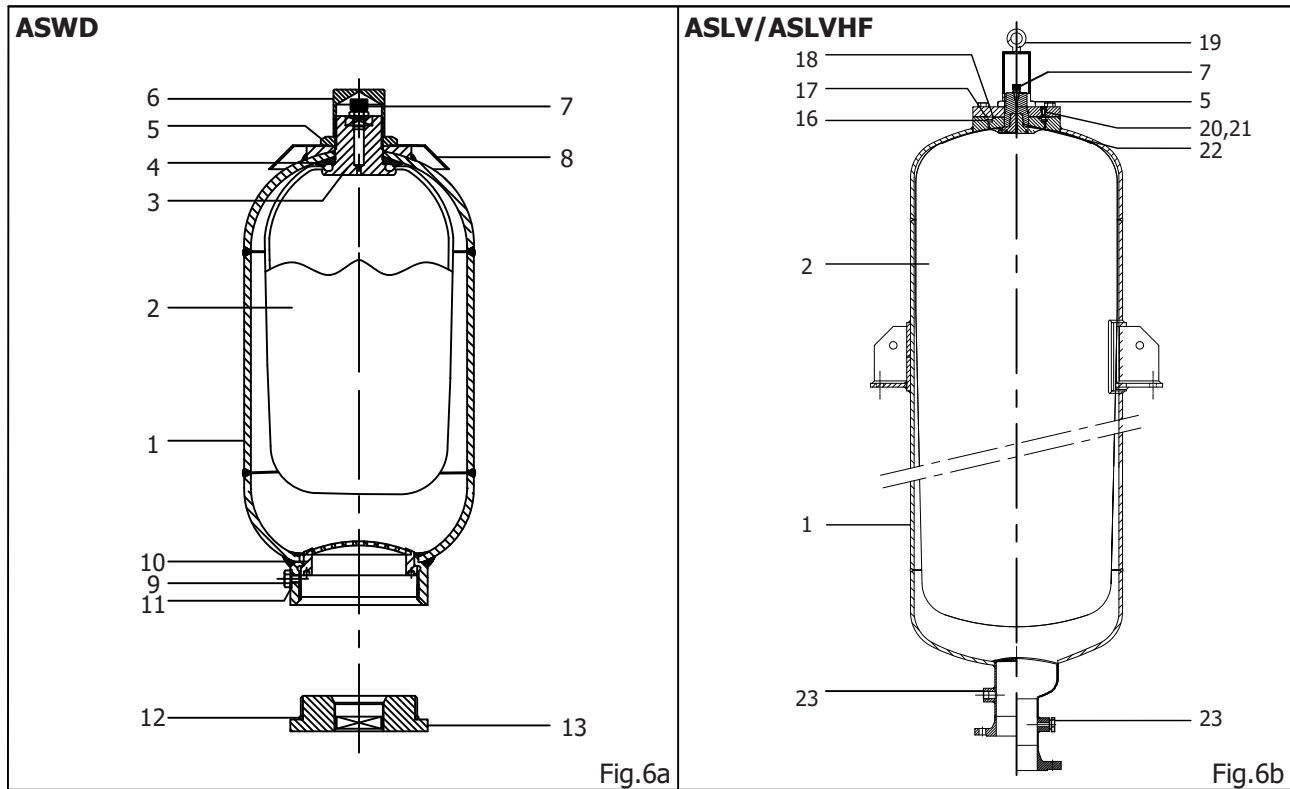

## Part Number \*

Item #	Description	Qty.	ASWD 1.5	ASWD 3	ASWD 4~5	ASWD 10~55	ASLV 100~575	ASLVHF 100~575
1	Accumulator Shell	1	-	-	-	-	-	-
2	Bladder	1	-	-	-	-	-	-
3	Gas Valve Body	1	B10107	B10107	B10202	B10333	-	-
4	Rubber-coated Washer	1	C10106	C10106	C10205	C10334	-	-
5	Gas Valve Lock Nut	1	E10109	E10109	E10109	E10302	GLN001	GLN001
6	Protection Cap	1	F10103	F10103	F10103	F10301	-	-
7	Gas Fill Valve	1	ASSY17	ASSY17	ASSY17	ASSY17	ASSY17	ASSY17
8	Name Plate	1	G10304	G10304	G10305	G10306	-	-
9	Bleed Screw	1	05XXXX	05XXXX	06XXXX	06XXXX	-	-
10	Seal Ring	1	C13384	C13384	C13384	C39XXX	-	-
11	Anti-Extrusion Assy.	1	I10445	I10445	I10446	I10421	-	-
12	Adaptor O-Ring	1	211026	211026	212013	257018	-	-
13	Adaptor	1	-	-	-	-	-	-
14	Gas Valve Assy.	1	A12022	A12022	A12042	A12062	-	-
15	Gasket Set	1	R12384	R12384	R12385	R12386	-	-
16	Circlip	1	-	-	-	-	265915	265915
17	O-Ring	1	-	-	-	-	273028	273028
18	O-Ring	1	-	-	-	-	255019	255019
19	Lifting Hook	1	-	-	-	-	LHOOK1	LHOOK1
20	Air Bleed Screw	1	-	-	-	-	H0508X	H0508X
21	Seal Ring	1	-	-	-	-	B51003	B51003
22	O-Ring	1	-	-	-	-	218028	218028
23	Drain Plug	1	-	-	-	-	GJXXXX	GJXXXX
	Gas Valve Assembly - consists item # 3 to 7	1	A12022	A12022	A12042	A12062	N/A	N/A
	Gasket Set - consists item # 17, 18, 22	1	N/A	N/A	N/A	N/A	GASK001	GASK001

\* For Carbon Steel & Nitrile components

# Ordering Code - Bladder Assembly

1	2	3	4	5	6
<b>S</b>	<b>35</b>	<b>P</b>	<b>M50</b>	<b>C</b>	<b>V</b>

1	<b>Design</b>	Refer Fig.8a & 8b	Standard Transfer Barrier Liquid Separator	= <b>S</b> (standard) = <b>ST</b> = <b>SL</b>
2	<b>Nominal Capacity (Ltrs)</b>	0.2 - 130 Ltrs (type : AS/ASHF/ASWD/ASWP) 100 - 575 Ltrs (type : ASLV/ASLVHF)		= <b>0.2-130</b> = <b>100-575</b>
3	<b>Bladder &amp; Seal material</b>	Nitrile (NBR) Butyl (IIR) Viton (FKM) Ehtylene-Propylene (EPDM) Hydrogenated Nitrile (HNBR) Neoprene (CR) Nitrile for Hydrocarbons Low Temp. Nitrile Epichlorohydrin (ECO) For foods		= <b>P</b> (standard) = <b>B</b> = <b>V</b> = <b>E</b> = <b>K</b> = <b>N</b> = <b>H</b> = <b>F</b> = <b>Y</b> = <b>A</b>
4	<b>Gas Valve type</b> (Refer page # 14 & 15)	<b>Gas Valve   Gas Fill Valve</b> Without   Without (only bladder) 5/8" UNF(M)   Integral - 5/8" UNF M22x1.5(M)   Various - screw-in M22x1.5(M) - special profile   Various - screw-in M22x1.5(M) 50mm extra long   Various - screw-in M30x1.5(M)   Various - screw-in M50x1.5(M)   Various - screw-in M50x1.5(M) 50mm extra long   Various - screw-in 7/8" UNF(M)   Various - screw-in 7/8" UNF(M)   Integral - Vg8 7/8" UNF(M) - special profile   Integral - Vg8 7/8" UNF(M)   Integral - 7/8" UNF M50x1.5 with 7/8" UNF(M)   Integral - 7/8" UNF M50x1.5 with 7/8" UNF(M)   Integral - Vg8 Integral valve   Integral ASLV/ASLVHF		= <b>0</b> = <b>U5/8</b> = <b>M22</b> = <b>M22-B</b> = <b>M22L</b> = <b>M30</b> = <b>M50</b> = <b>M50L</b> = <b>U7/8</b> = <b>U7/8V</b> = <b>U7/8V-B</b> = <b>U7/8U</b> = <b>MU7/8U</b> = <b>MU7/8V</b> = <b>LV</b>
5	<b>Gas Valve material</b>	Without Valve (only bladder) Carbon steel Nickel Coated carbon steel Stainless Steel Zn-Ni Coated Carbon Steel		= <b>0</b> = <b>C</b> (standard) = <b>N</b> = <b>X</b> = <b>Z</b>
6	<b>Gas Fill Valve connection</b>	5/8" UNF 5/8" UNF in Stainless Steel Without Gas Fill Valve/Transfert/Liquid Separator type 5/16" UNEF/Vg8 1/4" BSP M16x2.0 5/16" UNEF (7/8 UNF Gas Fill Valve Body) Double Lock Military Valve 7/8" UNF (Integral in 7/8 UNF Gas Valve) M28x1.5		= <b>V</b> (standard) = <b>X</b> = <b>0</b> = <b>1</b> = <b>2</b> = <b>3</b> = <b>4</b> = <b>8</b> = <b>9</b> = <b>M</b>

\* Before ordering, check for availability

## Design

The main feature of the bladder lies in an original and well developed EPE process by which the standard bladder being of **a single piece construction** without splices or joints and with a unique method for connecting gas valves, allows **various valves** to be fitted thus promoting considerable economic savings, especially when several accumulators of the same size, but with differing gas valves, are to be used in the same plant.

In addition, valves do not have to be replaced at the same time as the bladder.

The assembly of the valve to the bladder is a simple operation by use of a special rubber coated washer (Fig.19).

## Technical/constructional features

**THE BLADDER** used on standard version of the accumulator is in butadiene-acrilonitrile rubber, oil resistant (nitrile) suitable for operating temperature - 20°C to +85°C. Other materials as indicated in ordering code also available.

**THE GAS VALVE** is of phosphated carbon steel in the following three versions:

- S = STANDARD** - Fitted with gas fill valve suitable for stand-alone accumulators.
- ST = TRANSFERT** - For accumulators where additional gas bottles are used.
- SL = LIQUID SEPARATOR** - For applications where the bladder separates two liquids.

## Bladder dimensions

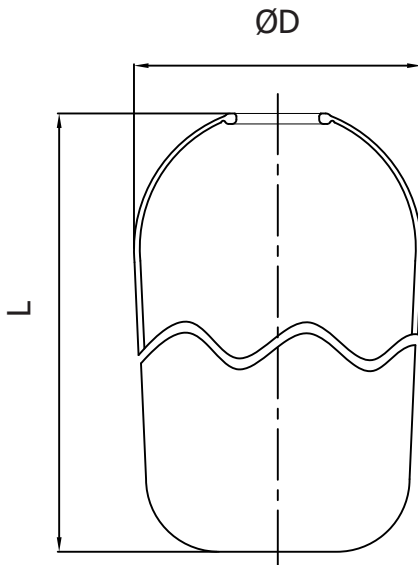
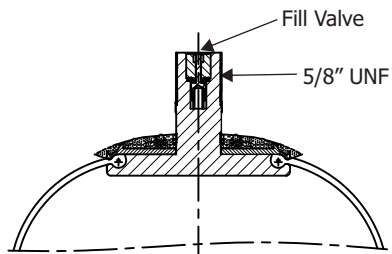

Fig.7

Model	ØD mm	L mm	Weight Kgs
S 0.2	38	148	0.03
S 0.7	74	120	0.06
S 1	95	131	0.13
S 1.5		193	0.17
S 2.5		318	0.30
S 3		362	0.35
S 4	145	198	0.39
S 5		273	0.42
S 6		343	0.46
S 10	198	305	0.92
S 12		360	1.10
S 15		440	1.30
S 20		580	1.75
S 25		750	2.15
S 28		910	2.50
S 35		1105	3.30
S 55		1538	4.60

Gas Valve types (refer Bladder Ordering Code - Page # 12)



Type : **U5/8**

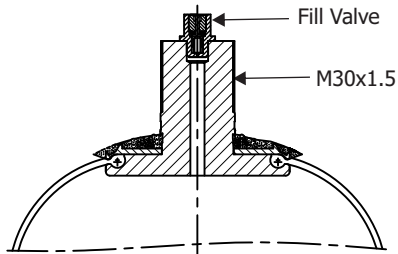

Type : **M30**

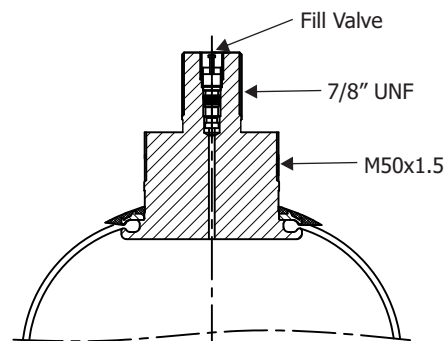

Type : **MU7/8U**

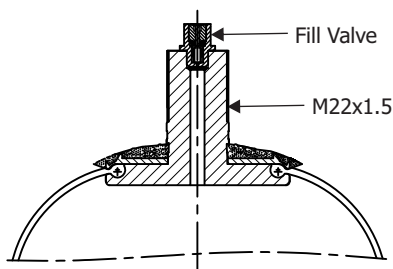

Type : **M22 & M22-B**

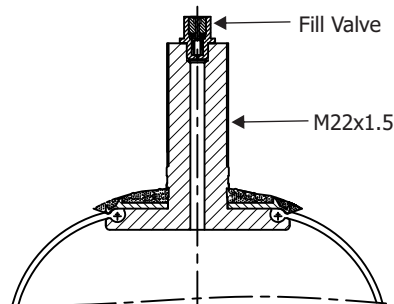

Type : **M22L**

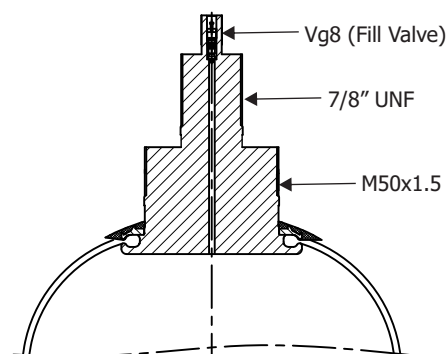

Type : **MU7/8V**

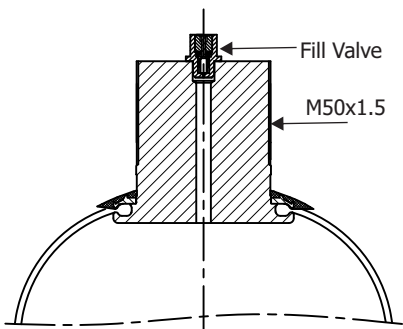

Type : **M50**

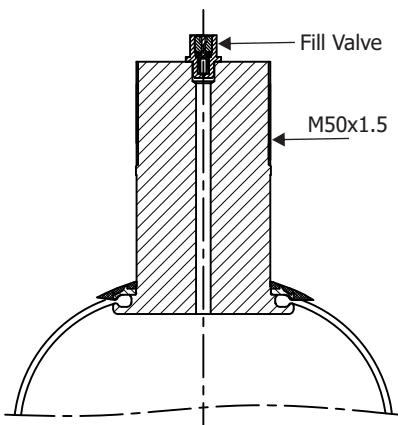

Type : **M50L**

Fig.8a

Gas Valve types (refer Bladder Ordering Code - Page # 12)

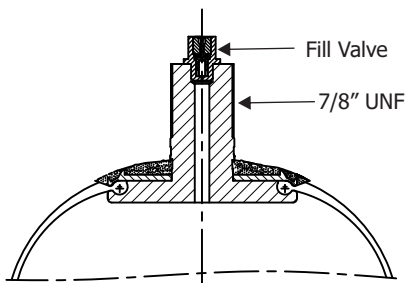

Type : **U7/8**

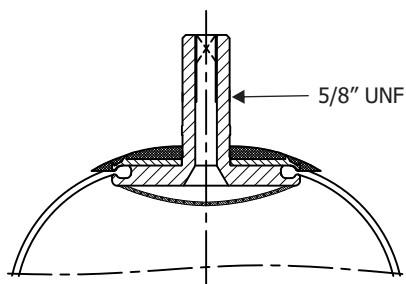

Type : **U5/8 (SL)**

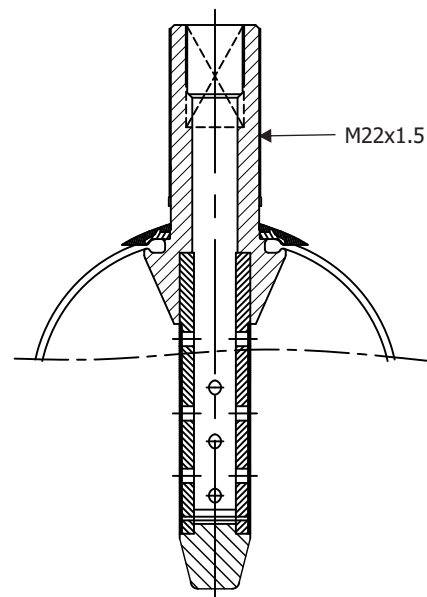

Type : **M22 (ST)**

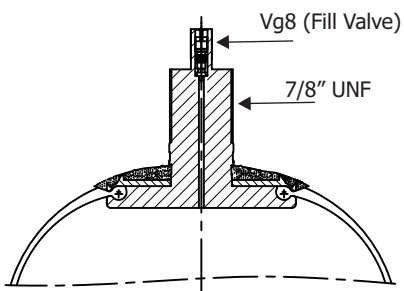

Type : **U7/8V & U7/8V-B**

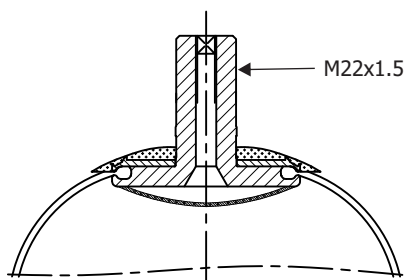

Type : **M22 (SL)**

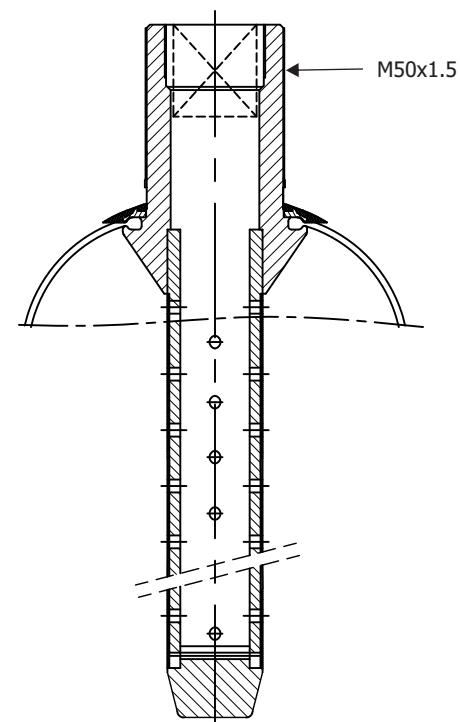

Type : **M50 (ST)**

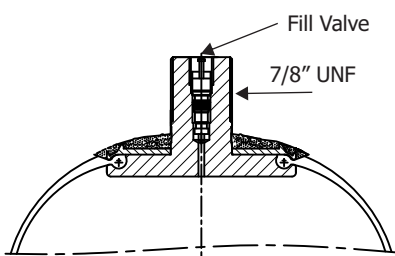

Type : **U7/8U**

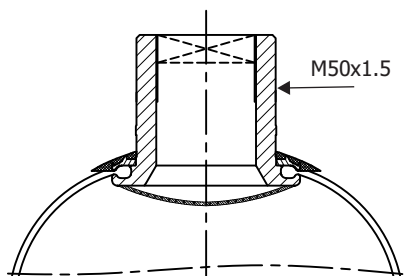

Type : **M50 (SL)**

Fig.8b



### Gas Valve types availability (refer Bladder Ordering Code - Page # 12)

Code	Description ↓   Capacity ⇒	0.2	0.7	1~3	4~6	10~55	60~130
0	Without Gas Valve (only bladder)	✓	✓	✓	✓	✓	✗
U5/8	5/8" UNF(M) with Integral 5/8" fill valve	✓	✓	✓	✓	✗	✗
M22	M22x1.5(M) Body for screw-in fill valve	✗	✓	✓	✓	✓	✓
M22-B	M22x1.5(M) Body for screw-in fill valve - for Bosch	✗	✗	✓	✓	✓	✗
M22L	M22x1.5(M) Body for screw-in fill valve - long body	✗	✓	✓	✓	✓	✓
M30	M30x1.5(M) Body for screw-in fill valve	✗	✗	✓	✓	✓	✗
M50	M50x1.5(M) Body for screw-in fill valve	✗	✗	✗	✗	✓	✓
M50L	M50x1.5(M) Body for screw-in fill valve - long body	✗	✗	✗	✗	✓	✓
U7/8	7/8" UNF(M) Body for screw-in fill valve	✗	✓	✓	✓	✓	✓
U7/8V	7/8" UNF(M) with Integral Vg8 fill valve	✗	✓	✓	✓	✓	✓
U7/8V-B	7/8" UNF(M) with Integral Vg8 fill valve - for Bosch	✗	✗	✓	✓	✓	✗
U7/8U	7/8" UNF(M) with Integral 7/8" fill valve	✗	✓	✓	✓	✓	✓
MU7/8U	M50x1.5/7/8" UNF(M) with Integral 7/8" fill valve	✗	✗	✗	✗	✓	✓
MU7/8V	M50x1.5/7/8" UNF(M) with Integral Vg8 fill valve	✗	✗	✗	✗	✓	✓
U5/8	5/8" UNF(M) - Liquid Separator design	✓	✗	✗	✗	✗	✗
M22	M22x1.5(M) - Liquid Separator design	✗	✓	✓	✓	✗	✗
M50	M50x1.5(M) - Liquid Separator design	✗	✗	✗	✗	✓	✓
M22	M22x1.5(M) - Transfert design	✗	✓	✓	✓	✗	✗
M50	M50x1.5(M) - Transfert design	✗	✗	✗	✗	✓	✓

✓=Available. ✗=Not available.

# Ordering Code | Dimensions - Gas Bottles

1	2	3	4	5	6
<b>BB</b>	<b>25</b>	<b>360</b>	<b>C</b>	<b>0</b>	<b>0</b>

1	<b>Design</b>	Accumulator Design Neck Design Threaded Design	<b>= BA</b> <b>= BB</b> <b>= BD</b>
2	<b>Nominal Volume (Ltrs)</b>	3-55 Ltrs (type : BA) 25-50 Ltrs (type : BB) 20-75 Ltrs (type : BD)	<b>= 3 - 55</b> <b>= 25 - 50</b> <b>= 20 - 75</b>
3	<b>Max. Pressure</b>	360 Bar	<b>= 360</b>
4	<b>Material</b>	Carbon Steel	<b>= C</b>
5	<b>Connections</b>	Standard Special	<b>= 0</b> <b>= S</b>
6	<b>Certification</b>	Factory tested CE/PED	<b>= 0</b> <b>= 8</b>

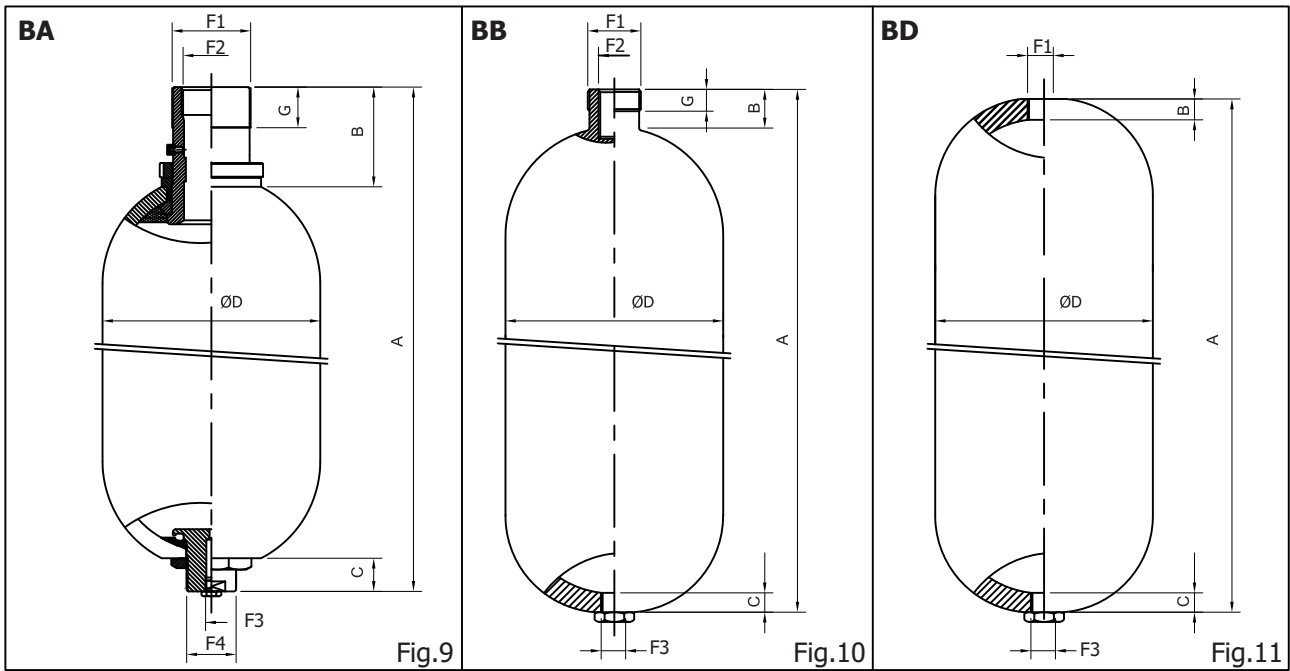

## Dimensions

Gas Bottle design	Model	Max. Pre. bar	Gas Vol. ltrs	Dry Wt. kgs	Fig	A	B	C	ØD	ØE	F1	F2	F3	F4	
Accumulator design	BA 3	360	3	11	8	525	64	25	114	46	1-1/2"	Ø33	1/4"	Ø20	
	BA 4		4	15		370									
	BA 5		5	17		435									
	BA 6		6	19		495	97	34	220						50
	BA 10		10	34		505									
	BA 15		15	44		685									
	BA 20		20	51		815									
	BA 25		24	59		950									
	BA 35		32	81		1340									
BA 55	50	114	1855												
Neck design	BB 25	360	25	48	9	970	70	18	219	50	2-1/2"	Ø50	1"	-	
	BB 35		35	64		1290									
	BB 50		50	89		1765									
Threaded design	BD 20	360	20	40	10	745	21	18	219	-	1"	-	3/4"	-	
	BD 25		25	48		905									
	BD 35		35	65		1225									
	BD 50		50	89		1700									
	BD 75		75	130		2500									

\* Check availability before ordering.

# Accumulator Stations

## General

When the flow rate or the demand from accumulator exceeds a single accumulator, accumulator stations are deployed which are pre-fitted with valves and piping as desired by the user to reduce installation time.

Single row stands of 2 to 5 accumulators (Fig.13) or double row stands of 4 to 10 accumulators (Fig.12) are normally assembled.

## Construction

The accumulators are mounted on a fabricated steel frame painted with a coat of rust inhibitor.

Depending on the quantity and the overall size, the accumulators can be positioned in one row (Fig.13) or in two rows (Fig.12). Each accumulator rests on a rubber support ring, fastened with clamps, fitted with safety valve, piping and fitting.

A delivery manifold (dimensions determined by the flow rate and operating pressure) connects the various blocks. The two ends have a BSP female thread, or, on request, are flanged. One of the ends is closed off with a plug or blind flange. The manifold linking the discharge outlets of each block follows the same pattern. If requested, a pressure gauge or pressure switch to control the delivery pressure and a oil drip tank can be included. The double stand may also be used for installing transfer accumulators connected up to additional, parallel mounted, nitrogen bottles. A number of variants can be supplied. To make the best choice contact our technical team.

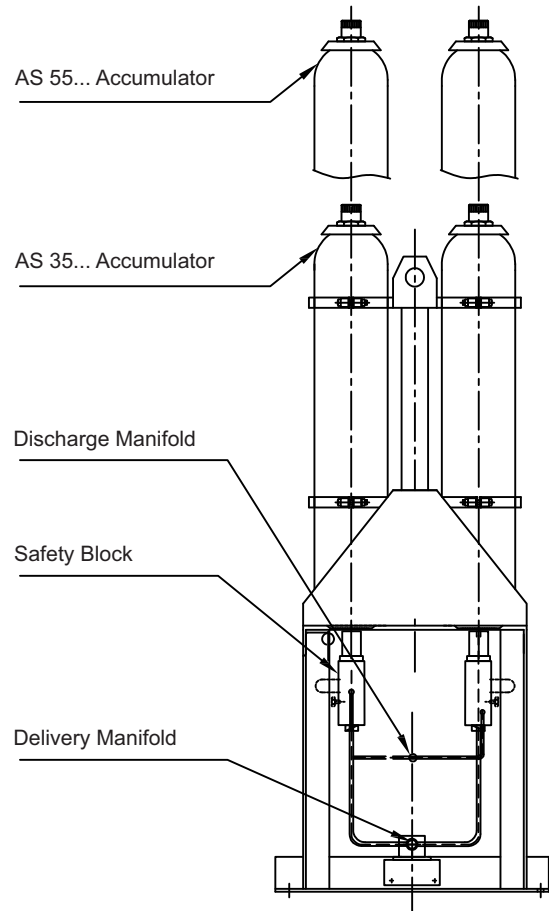

Fig.12

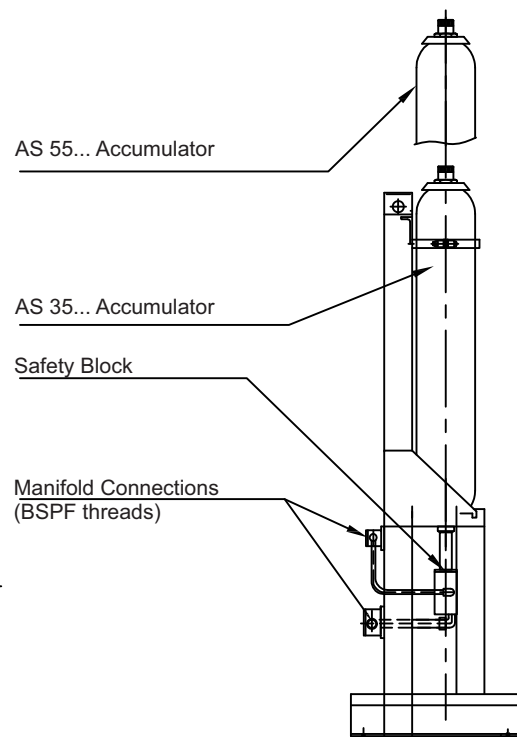
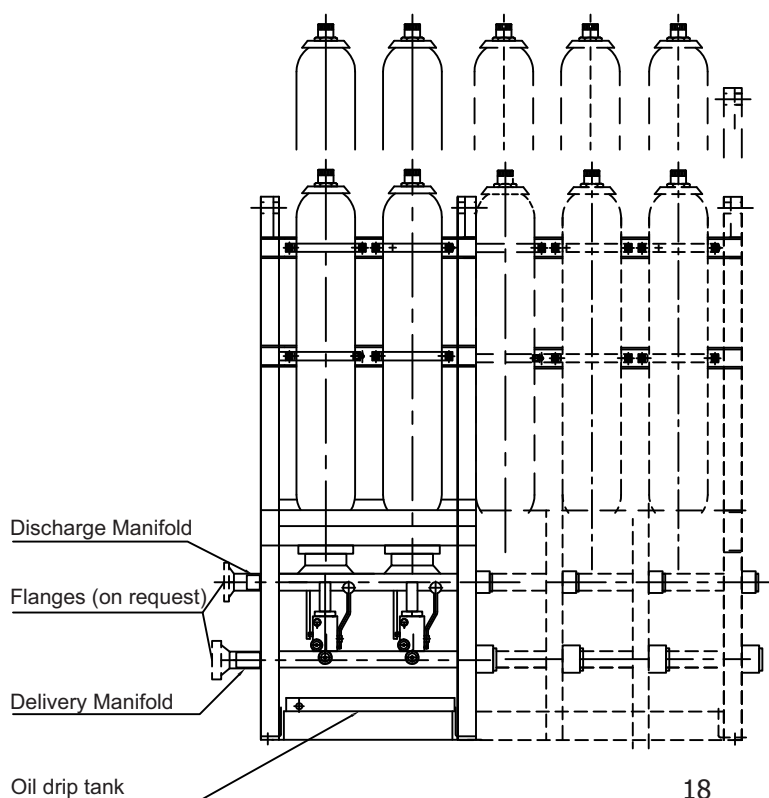

Fig.13

## General

All EPE accumulators are carefully inspected and tested at the factory and are exactly as designated by the code printed on the name plate.

In addition the name plate carries the accumulators serial number and if specified on order, the value on precharge.

On the accumulator shell are also marked :  
Manufacturer's serial number & date shell manufactured;  
identification mark; design standard applicable; maximum recommended working pressure; temperature range; capacity in liters.

Accumulators are normally supplied empty (uncharged). Nitrogen precharged units can be supplied on request.

**ATTENTION:** The max working pressure marked on the accumulator must be  $\geq$  that the calibrated pressure of the relief valve.

Before undertaking any work on the hydraulic circuit for mounting an accumulator, it is required to release the pressure completely.

Test certificates if required are supplied with the accumulator, or forwarded by mail.

## Installation

To achieve a high degree of efficiency, the accumulator should be fitted as close as possible to the installation it serves.

The space necessary for testing and filling equipment is at least 150mm above the gas-fill valve.

POSITION is possible from vertical one (gas valve on top) to the horizontal one.

The manufacturers name plate stating initial pressure must remain visible.

Access to vent screw must be kept unobstructed.

**MOUNTING** by means of clamps, brackets and rubber support rings.

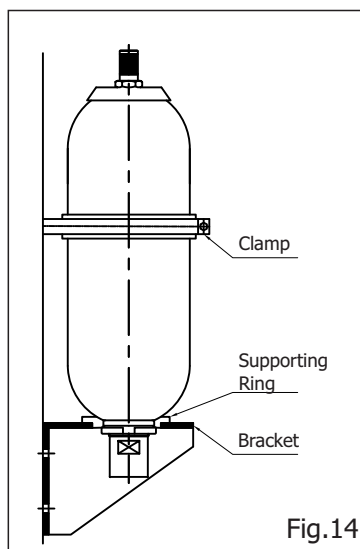

The mounting must be such that should a rupture occur on the pipe system at the liquid connection, or should the gas-fill valve break, the accumulator cannot be pulled from its mounting by the forces involved.

No welding or other mechanical process must be carried out on the accumulator shell for the purpose of attaching fastenings.

CONNECTION adopters and flanges are available on request. When fitting screws, reducers or the safety and shut-off block, care must be taken that the accumulator is held firmly by means of a spanner at the liquid valve, so that the liquid valve is not turned independently of the accumulator body.

To guarantee trouble free operation, the following points should be observed:

- A non-return valve to be fitted between pump and accumulator to prevent reversal.
- A relief valve must be fitted close to the accumulator and set at lower than the max. working pressure marked on the accumulator shell.
- A shut-off valve and a dump valve are recommended to enable periodic checks or removals during normal operation. EPE safety blocks **Type B** incorporate all the essential functions.

## Preliminary Checking

Upon receipt check:

That there has been no damage in transit.

The identification code is as ordered.

Before installation it is most important to ensure that the gas pressure corresponds to the desired value.

The initial gas pressure must be selected to meet the service requirement.

In general the design values are as follows:

$P_0 = 0.9 P_1$ , ( energy reserve, line shock absorber, etc.)

$P_0 = 0.6 - 0.7 P_1$  ( pulsation damper )

Gas precharge pressure is of crucial importance to the correct functions of the accumulator and the durability of the bladder.

The gas pressure, when the accumulator is supplied pre-charged is related to the temperature of 20°C.

In the case of accumulators supplied without pre-loading pressure, or after repair work it is necessary to perform inflation with nitrogen; must also be performed also the verification of the system by using the equipment type-PC following procedure - Checking & Charging - page-20.

# Operation & Maintenance

## Initial Operation

Before the system is pressurised it has to be bled. For this, the vent screw in the fluid port assembly has to be eased until fluid emerges.

Then retighten the gas valve locknut carefully.

The system is charged with maximum pressure and sealings and connections should be checked.

## Periodic Checking

After the installation of a new unit, or following repairs, the initial pressure must be tested as follows:

Atleast once during the first week so that any gas losses can be immediately observed and remedied.

If no gas losses are observed during the first check, a second check should be carried out approximately 3 months later,

If during this check no gas losses are evident, a six-month check should be sufficient.

It is however recommend that heavy duty applications be checked every month.

## Checking & Charging

Pre-Loading & Checking Set type-PC (refer Fig.15) is to be used for checking / charging of Bladder Accumulators. When charging, the nitrogen bottles must be capable of delivering pressure higher than the desired accumulator gas pressure.

Use dry industrial nitrogen. NEVER USE OXYGEN OR AIR.

Proceed as follows:

- Fit the suitable pre-charging equipment to the gas valve;
- Connect it to the nitrogen cylinder with the charging hose;
- Slowly introduce nitrogen into the accumulator until reaching a pressure slightly above the required level;
- Close the valve of nitrogen cylinder and disconnect the charging hose from the equipment;
- Wait for the gas temperature stabilization;
- Set the pressure by venting off the excess of gas.

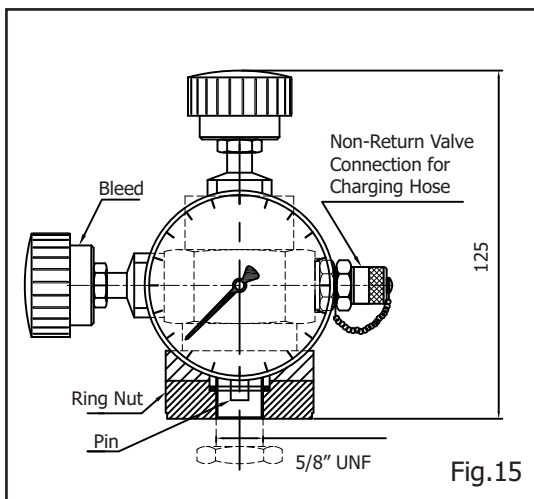

Fig.15

It is important that the gas pressure be kept constant and should therefore be checked periodically by means of the filling and checking equipment PC/...

The same equipment is used for re-inflating the bladder after repair work or change of use.

Connection is made by the special hose to the dry nitrogen bottle.

ONLY NITROGEN MUST BE USED. AIR OR OXYGEN COULD CAUSE AN EXPLOSION.

## Pressure Checks

This is simple operation, the correct procedure is as follows:

- Isolate the accumulator from the system and reduce the liquid pressure to zero.
- Remove the protective and sealing caps from the gas valve.
- Prior to the mounting PC/ - equipment ensure that the valve A is unscrewed, that bleed valve B is closed and that is non-return valve C is screwed tight. (refer Fig.16)
- Attach the unit to the gas-fill valve by means of the knurled nut D.
- Screw valve A to a point where pressure is registered.

If the pressure is OK remove the PC/unit as follows:

- Unscrew the valve A.
- Open the bleed valve B and unscrew the nut D.

## Pressure Reduction

If the pressure has to be reduced this is done by opening the bleed valve B slowly until the correct pressure is registered on the gauge.

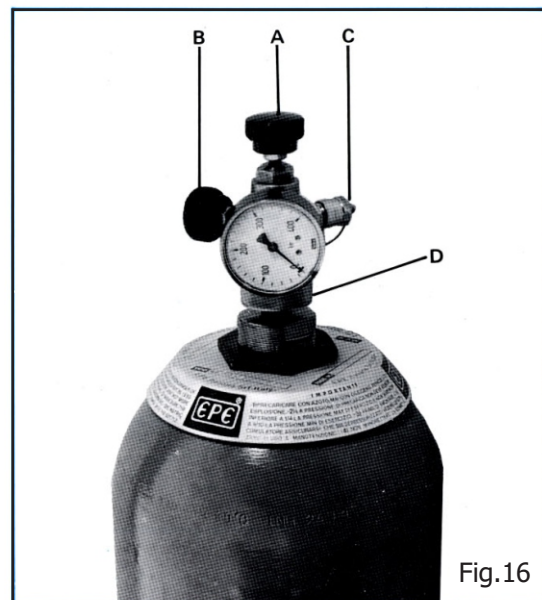
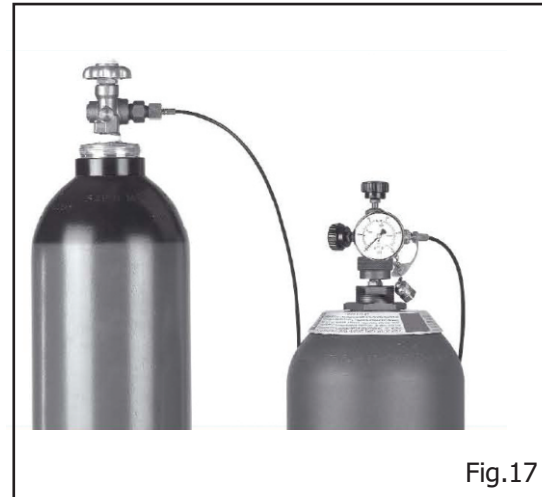

Fig.16

## Increase or reset precharge pressure

If it is necessary to fill, or to increase the gas pressure, proceed as follows:

- Fit the PC/ unit as described above.
- Fit the connection to nitrogen cylinder. (refer Fig.16 & Fig.17)
- Connect the hose between the cylinder and the non-return valve C.
- Slowly open the valve on the cylinder till the gauge registers a pressure slightly higher than the one desired, then shut.
- Unscrew A and reduce the pressure PC/ unit to zero by means of the bleed valve B.
- Disconnect the hose from the non-return valve C. and replace cap.
- Close the bleed valve and wait approximately 5 mins. for the temperature to adjust.
- Screw valve A until the pressure can be read. This should be slightly higher than the desired pressure.
- Adjust by means of bleed valve, remove the filling unit.
- Use soapy water test for leaks.
- Replace the valve cover and protection cap.



Standard equipment PC-280/70 is supplied with two pressure gauges: the high pressure gauge (0-280 bar) is used for pre-loading values higher than 50 bar and low pressure gauge (0-70 bar) for values lower than 50 bar.

The accumulator is ready for use.

**A PRESSURE REDUCING VALVE MUST BE INSTALLED BETWEEN THE NITROGEN GAS CYLINDER AND THE ACCUMULATOR WHEN THE GAS CYLINDER PRESSURE IS HIGHER THAN MAX PERMISSIBLE PRESSURE OF ACCUMULATOR.**

## Tightening Torque Values (Nm)

Component ↴ \ Size ⇨	0.2	0.7 to 1.5	3 to 6	10 to 55	60 to 130
Fluid Port Ring Nut	50 + 15	90 + 15	200 + 20	440 + 60	600 + 60
Bleed Screw	3 + 1	5 + 1	5 + 1	30 + 10	30 + 10
Gas Valve Lock Nut	50 + 10	80 + 20	80 + 20	140 + 40	140 + 40
Gas Fill Valve	-	30 + 5	30 + 5	30 + 5	30 + 5
Valve Insert	-	0.3 + 0.2	0.3 + 0.2	0.3 + 0.2	0.3 + 0.2



## General

If the Accumulator has to be stripped for any reason, the following procedure must be followed in the sequence shown below.

Before removing Accumulators for servicing, the fluid pressure must be reduced to zero by exhausting the fluid through the system and back to the reservoir.

When this is not possible the Accumulator shut-off valve must be closed and the dump valve opened to exhaust the Accumulator directly to the reservoir.

As the liquid connections for the HP & LP Accumulators differ the procedure will also vary.

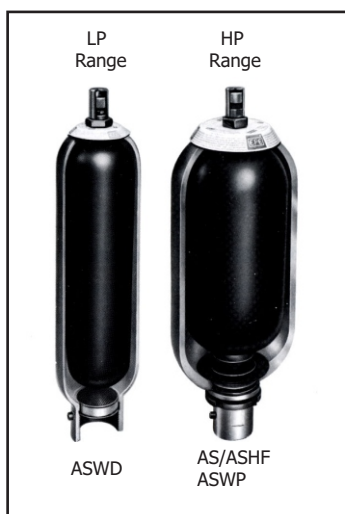

Fig.18

## Dismantling the Accumulator

- Isolate from the liquid connection and drain.
- Place the Accumulator in a vice horizontally.
- Remove the protection caps.
- Discharge gas from the bladder by means of pre-loading & checking device. (Fig. D-1).
- Dismantle the gas-fill valve.

Only at this point can the liquid connection be dismantled.

## High Pressure Range (AS/ASHF/ASWP):

- Remove the bleed screw. (Fig. D-2)
- Remove the ring nut and the spacer ring. (Fig. D-3)
- Push the fluid port body into the vessel and remove the gasket and 'O'Ring. (Fig. D-4)
- Remove by bending the rubber coated retaining ring. (Fig. D-5)
- Remove the fluid port body. (Fig. D-6)
- Remove the nut holding the gas valve and nameplate. (Fig. D-7)
- Remove the bladder from the liquid side by slightly twisting. (Fig. D-8)

## Low Pressure Range (ASWD):

- Remove the bleed screw.
- Unscrew the anti-extrusion body assembly.
- Remove the nut holding the gas valve and nameplate.
- Remove the bladder from the liquid side by slightly twisting.

## Cleaning and inspection

Carefully clean all components including the bladder and the inside of the Accumulator body.

Mainly check that:

- THE BLADDER is not damaged, worn or perished.
- THE POPPET VALVE in High Pressure Range (types - AS / ASHF / ASWP) slides freely and that the spring is undamaged.
- GASKETS AND SEALS are not worn.
- THE INTERIOR of Accumulator body has no cracks or signs of failure.
- THE ANTI EXTRUSION plate in Low Pressure Range (type-ASWD) is not damaged or worn.

REPLACE ALL SUSPECT AND WORN PARTS. THE BLADDER CAN'T BE REPAIRED.

**WARNING : Before any work is undertaken the gas pressure must be fully relieved.**

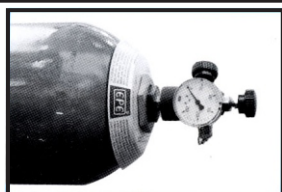

D-1



D-2

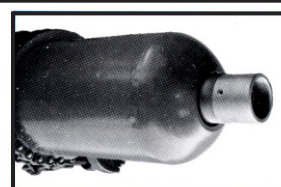

D-3

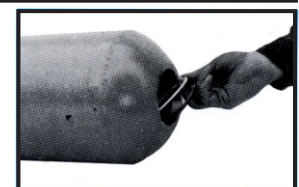

D-4



D-5



D-6



D-7

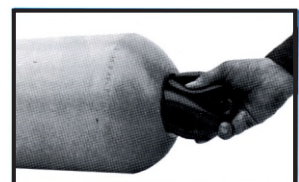

D-8



## Bladder Gas Valve Assembly

Should the bladder have to be replaced and the gas valve is in good condition it is possible to fit a new bladder to the old gas valve (or vice-versa) taking care to ensure that the edge of the mouth piece makes a perfect fit with the valve seat. The valve is then put into place, by means of hand pressure on the rubber coated washer until it is no longer possible to remove unless force is used. The bladder can now be inserted into the Accumulator.

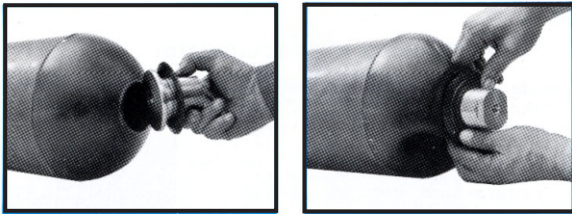

Fig.19

## Assembling the Accumulator

Ensure that all components are in good condition and perfectly clean. Assemble in the following order:

### High Pressure Range ( AS / ASHF / ASWP):

- Insert the bladder (use a threaded tube M 12 x 1.5). (Fig. A-1)
- Mount name plate and nut for the gas valve body. (Fig. A-2)
- Tighten the nut holding the gas valve body with a spanner. (Fig. A-3)
- Insert the fluid port assembly and the rubber coated retaining ring. (Fig. A-4)
- Locate the fluid port on to the support ring, fit gaskets and spacer ring. (Fig. A-5)
- Tighten the ring nut making sure the assembly is centrally located. (Fig. A-6)
- Fit the bleed screw and gasket. Pour a small amount of liquid into the accumulator to lubricate. (Fig. A-7)
- Finally mount the gas-fill valve, charge accordingly to Checking & Charging - page-20 and again tighten the gas valve nut.

### Low Pressure Range (ASWD):

- Insert the bladder (use a threaded tube M 12 x 1.5)
- Mount name plate and nut for the gas valve body.
- Tighten the nut holding the gas valve body with a spanner
- Tighten the anti-extrusion body assembly.
- Tighten the reducer assembly.
- Fit the bleed screw and gasket. Pour a small amount of liquid into the Accumulator to lubricate.
- Finally mount the gas-fill valve, charge accordingly to Checking & Charging - page-20 and again tighten the gas valve nut.

### Large Volume Range ( ASLV / ASLVHF)

Refer page # for the spare parts information.

- Remove lifting hook (Item # 19)
- Connect charging kit type PC to the Gas Fill Valve (Item # 7) and discharge the accumulator completely.
- Remove Gas Fill Valve (Item # 7).
- Connected a threaded tube (M12 x 1.5) onto the gas valve.
- Remove Air Bleed Screw (Item # 20) & Seal Ring (Item # 21) to bleed the air in the vessel.
- Remove Gas Valve Lock Nut (Item # 5).
- Unscrew the nuts and remove the Top Cover.
- Remove the Circlip (Item # 16).
- Pull the bladder assembly upwards (from the gas side) pressing the bladder and slightly twisting.
- Once the bladder is completely taken out of the shell inspect the bladder and o-rings (Item # 17, 18 & 22).
- Replace the damaged components.

For reassembly follow the above procedure in reverse order. While reassembling ensure the bladder surface is suitably oiled with the system fluid.

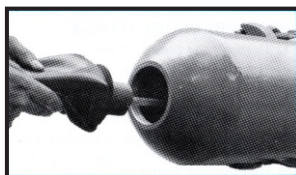

A-1



A-2

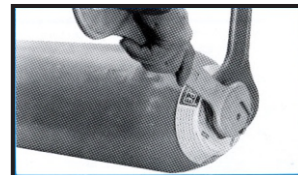

A-3



A-4



A-5

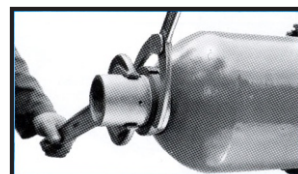

A-6

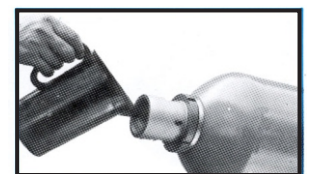

A-7

# Special Instructions

---

## Certification

All hydraulic accumulators are pressure vessels and are subject to the national regulations and directives, valid at the place of installation.

Bladder accumulators type AS are generally designed and manufactured according to European Directive.

As per the provisions of the European Directive all accumulators with  $V \leq 1$  ltr and  $PS \leq 1000$  bar ( $PS = \text{max. working pressure in bar}$ ) are not allowed to be CE marked [Articles 3; 1.1 and 1.4 (3)].

Accumulators of capacity greater than 1 ltr are available with CE marking. When specified every shipping batch is provided with a conformity declaration and use and maintenance instructions.

## Safety

All pressure vessels must be protected by means of a pressure relief valve in accordance with European Directive. Safety Blocks are used for this purpose.

The most important elements of the safety-related equipment are the pressure measuring device (pressure gauge), device for the preventing excess pressure (safety valves), non-return valves and shut-off valves and devices for de-pressurising (bleed valves). These functions can be performed with individual components or integrated in the form of a safety block.

## Special Instructions

It is strictly forbidden to:

- weld or solder or carry out any mechanical operations on the accumulator.
- engrave or permanently stamp the surfaces of the accumulator shell and / or carry out other operations that could affect or change the mechanical properties of the accumulator
- use the accumulator as a structural element: it should not be subjected to stresses or loads.
- change the data of the nameplate and / or accumulator without the permission of the manufacturer.
- use a different fluid than those designed for.

## Installation

Before installation, you must perform a visual check to verify that the accumulator has not suffered any damage during shipping / handling. Verify that the requested type matches with what stamped on the nameplate.

We recommend using the accumulator with a suitable safety valve or a security safety block. This device provides user and equipment protection against possible damage caused by pressure surges, and also makes the maintenance of the accumulator easier, so facilitating the interception and the discharge.

Provide for a clearance of 200 mm above the gas pre-charge valve to allow access to and control of the pre-charge equipment.

These accumulators may be installed in any position from horizontal to vertical (preferably with the pre-charge valve at the top), and the identification details must be visible.

Proceed to the assembly so that no abnormal force affects the pipes connected directly or indirectly to the accumulator, so we recommend the use of supporting components and also fastening to avoid the transmission of vibrations.

Make sure the fluid is compatible with the elastomer of the bladder.

Check that the max. allowed accumulator pressure is equal to or greater than that of the hydraulic circuit and that the temperature during operation is maintained within the range expected.

Make sure the fluid does not contain contaminants and/or abrasive.

## Disposal

Before the accumulator is sent for disposal or recycling, it should always be discharged completely of the pre-charge pressure and the gas valve unscrewed. Pre-loading and checking kits are suited for this task.

## Environmental Protection

Careless disposal of the accumulator and the residual fluid contained therein can cause environmental pollution.

Dispose the Accumulator in accordance with provisions applicable in the country of use.

Fluid residues are to be disposed according to the respective safety data sheets valid for the specific hydraulic fluids.