



Filters . Accumulators

Heavy Duty Filter

Inline mounting
Type : 160-OFM20X

Technical Data

Design : Simplex Inline
 Max. Pressure (PS) : 160 bar [2321 psi].
 Test Pressure (PT) : 1.43 x PS (as per CE/PED)
 1.3 x PS (as per ASME)
 Temperature range : -20°C to +100°C (Standard)
 -4°F to +212°F (Standard)
 Connection : SAE 1-1/2" / G1-1/2"
 Element design : EPE standard

Material of Construction

Head : GGG40/GGG50.
 Bowl : Carbon Steel.
 Seals : Nitrile / Viton / EPDM.
 Paint : Bowl Externally painted in RAL-5010.
 Others on request.

Flow Capacity

0020 200 lpm [50 gpm]
 0030 300 lpm [65 gpm]
 0045 450 lpm [100 gpm]



Hydraulic Symbol

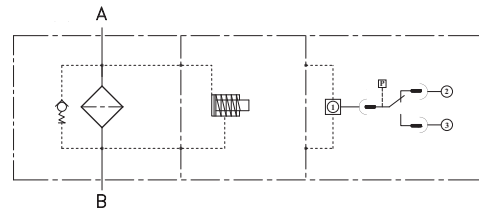

Description

The 160-OFM20X series Filters are designed exclusively for heavy duty applications and used for direct installation in the pipeline to provide wear protection of downstream components & systems.

Simplex in design for inline mounting the filter inlet & outlet are located the opposite sides. The flow path arrow (inlet to outlet) is marked on filter head.

The Filter head is provided with an element locating spigot. The Filter bowl - provided with radial sealing to ensure leak-free jointing - is mounted below the filter head and is unscrewed for maintenance.

Accessories

Maintenance indicator - for monitoring the filter element contamination status. Available in various designs including

- Pressure switch - NO, NC and switch-over.
- DP - Optical (pop-up version) with Electrical option.
- DP - Optical (dual dial version) with Electrical option.
- DP - Optical-Electrical with 2 switching points.
- Bypass valve - to protect the filter element during start-up and over pressurisation due to clogging.

Vent valve - for removing the air from the filter during starting and for safe depressurisation.

Drain valve - for draining the filter during servicing.

Filter Element

The Filter Element is of star-pleated design with optimised pleat density for providing prolonged life.

The filter element is of Out-to-In design and the contaminant is retained outside the filter element and collected in the filter bowl.

The elements are available in various media options and selected based on the required oil cleanliness, initial pressure drop and dirt holding capabilities.

- Media options for the filter element include
- SS Wire Mesh - Cleanable, Nominal filtration.
 - Paper - Non-cleanable, Nominal filtration.
 - Non-woven - Non-cleanable, Nominal filtration.
 - Inorganic glass fibre - Non-cleanable, Absolute filtration acc. to ISO-16889.
 - Aquasorb - Water absorbing media, Non-cleanable.

For special applications / fluids the filter elements are supplied with SS hardware (end caps & inner tube) and / or different adhesives.

Technical specifications subject to change.

Ordering Code - Filter

1 2 3 4 5 6ab 7 8 9ab 10 11 12 13
160 - **OFM20X** - **0030** - **H10XP** - **A** - **0** **P** - **0** - **0** - **A5.0** - **G08** - **P** - **0** - **IL** /

1	Max. working pressure	160 bar [2321 psi]	= 160
2	Filter type	Heavy Duty Inline - EPE Standard Element	= OFM20X
3	Nominal Size	Filter type OFM20X	= 0020 0030 0045
4	Filtering Media & Filtration Grade	<u>Nominal Filtration Grade</u> SS Wire Mesh Cleanable with additional epoxy layer upstream for 10/25/40µm	= G10 G25 G40 G60 G80 G100 Others on request
		Paper Non-cleanable with epoxy mesh	= P5 P10 P25
		Non-Woven Non-cleanable with epoxy mesh	= VS10 VS25 VS40 VS60
		<u>Absolute Filtration Grade (ISO16889)</u> Glass Fibre Non-cleanable with epoxy mesh	= H1XL H3XL H6XL H10XL H16XL H20XL
		Long Life Glass Fibre Non-cleanable with plastic mesh & outer sleeve	= H3XP H5XP H10XP H15XP H20XP
		Long Life Glass Fibre Non-cleanable with epoxy mesh	= H3XE H5XE H10XE H15XE H20XE
		Glass Fibre - Electrically Conductive Non-cleanable with epoxy & SS mesh	= H3XC H6XC H10XC H20XC
		Glass Fibre - Water Absorbing Non-cleanable with epoxy mesh	= AS1 AS3 AS6 AS10 AS20
		SS Fibre Cleanable with SS mesh	= M5 M10 M15
5	Differential Pressure of Element	<u>Maximum allowed differential pressure</u> 30 bar [435 psid] 60 bar [870 psid] 160 bar [2321 psid]	= A (standard) = D = C
6a	Element Adhesive	Standard Adhesive T=100°C [212°F] Epoxy Adhesive (for fuels) High Temp. Adhesive T=160°C [320°F]	= 0 (standard) = 1 = E
6b	Element Hardware (End Caps + Inner Tube)	Carbon Steel + Carbon Steel Polyamide + Carbon Steel Stainless Steel + Stainless Steel Nickel Coated CS + Nickel Coated CS Carbon Steel + Stainless Steel	= C (standard) = P (standard) = X = D = M
7	Magnet	Without	= 0 (standard)

* Before ordering, check for availability.

Ordering Code - Filter

1 2 3 4 5 6ab 7 8 9ab 10 11 12 13
160 - **OFM20X** - **0030** - **H10XP** - **A** - **0 P** - **0** - **0** - **A5.0** - **G08** - **P** - **0** - **IL** /

8	Bypass Valve	<p>Without With Bypass Valve - 0.3 bar [4.35 psid] With Bypass Valve - 0.8 bar [11.6 psid] With Bypass Valve - 1.5 bar [21.7 psid] With Bypass Valve - 2.0 bar [29.0 psid] With Bypass Valve - 2.5 bar [36.2 psid] With Bypass Valve - 3.0 bar [43.5 psid] With Bypass Valve - 3.5 bar [50.7 psid] With Bypass Valve - 5.0 bar [72.5 psid] With Bypass Valve - 7.0 bar [101.5 psid] With special setting Bypass valve</p>	<p>= 0 (standard) = 1 = 2 = 3 = 4 = 5 = 6 = 7 = 8 = 9 = Bx (x = pressure bar)</p>
9a	Maintenance Indicator - type	<p>Without DP - Optical (Pop-up) DP - Optical + Electrical with DIN Plug DP - Optical + Electrical with Lamp DP - Optical + Elec. - 2 Switching points - set to operate at 75% and 100% Pressure Switch - Electrical - Closer - NO Pressure Switch - Electrical - Opener - NC Pressure Switch - Electrical - Switch-over Pre Sw. - Optical+Elec. - Switch-over+lamp</p>	<p>= 0 (standard) = A.. = B.. = D.. = T.. = PSD.. = PSF.. = PSG.. = PSK..</p>
9b	Maintenance Indicator - cracking pressure	<p>Without 0.8 bar [11.6 psid] 1.5 bar [21.7 psid] 2.5 bar [36.2 psid] 4.2 bar [60.9 psid] 5.0 bar [72.5 psid] 6.0 bar [87.0 psid] 7.0 bar [101.5 psid] Other pressure (in bar)</p>	<p>= - (standard) = ..0.8 = ..1.5 = ..2.5 (std for Pre Ind) = ..4.2 = ..5.0 (std for DP Ind) = ..6.0 = ..7.0 = as applicable</p>
10	Inlet / Outlet - connections	<p>BSP Thread (ISO-228) - 1-1/2" BSP(F) SAE 1-1/2" #3000 with UNC Threads SAE 1-1/2" #3000 with Metric Threads SAE Straight Thread O'Ring Boss (J1926) With adaptor</p>	<p>= G08 (standard) = SOU = SOM = S24 (refer pg.5) = RAO (to be specified)</p>
11	Seal Material	<p>Nitrile Viton EPDM Neoprene</p>	<p>= P (standard) = V = E = N</p>
12	Housing Material	<p>Standard - as per catalogue Special</p>	<p>= 0 (standard) = SP</p>
13	Other Options (multiple options possible)	<p>Standard - without indicator ports Design-1: Inlet on Left - Indicator in front Design-2: Inlet on Right - Indicator in front With 1/4" air vent port - duly plugged With 1/4" BSP Air Vent Valve With 1/4" drain port - duly plugged</p>	<p>= 0 (standard) = IL (Standard) = IR = EP = E = 4</p>

* Before ordering, check for availability

Ordering Code - Filter Element

Ordering Code - Seal Kit

2. **0030** - **H10XP** - **A** - **0 P** - **0** - **P**
 3 4 5 6ab 11

D - **160** - **OFM20X** - **0030** - **A** - **G08** - **P** - **0**
 3 1 2 3 9a 10 11

Maintenance Indicators

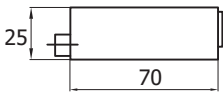
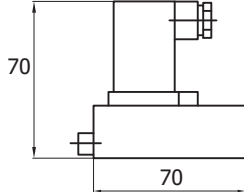
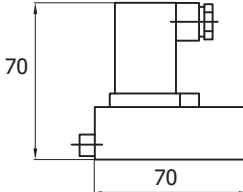
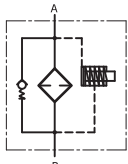
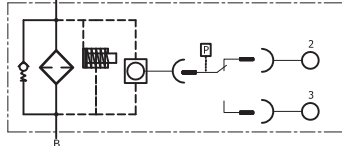
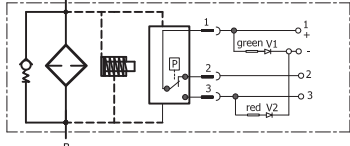
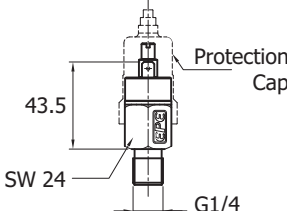
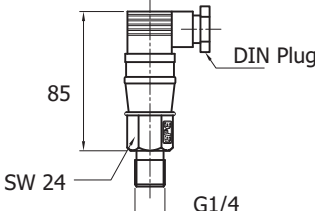
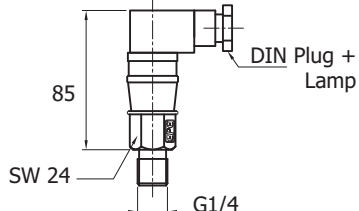
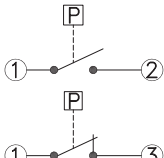
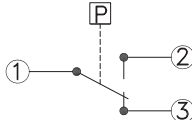
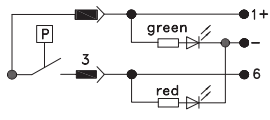
		
A = Optical (Pop-up)	B = Optical (Pop-up) + Electrical	D = Optical (Pop-up) + Electrical with 2 LEDs
Ordering Code F-xx-A0-00-00-P	Ordering Code F-xx-GW-02-00-P	Ordering Code F-xx-GW-26-00-P
		
		
PSD = Electrical Closer - NO PSF = Electrical Opener - NC	PSG = Electrical - Switch-over with DIN Plug	PSK = Electrical Switch-over + Lamp
Ordering Code PSD = Hxx-HS-32-00-P PSF = Hxx-HA-32-00-P	Ordering Code Hxx-GW-33-00-P	Ordering Code Hxx-GS-34-00-P
		

Maintenance Indicator functioning

The pressure switches are mounted upstream and preferred in return line application. Available in NO, NC & Switch-over versions with 1-2 terminals for NO & 1-3 terminals for NC circuit.

The DP indicators work on the differential pressure and operate when a preset pressure differential is reached between the inlet & outlet ports. In the pop-up version a red indicator pin pops out in the housing chamber thereby indicating the state whereas in the dual dial version two dial gauges - with green, yellow & red bands - placed on opposite side indicate the condition. If available, the electronic switching element is also triggered.

In the 2-switching points version (type T) the green LED glows in operating condition, yellow LED glows when 75% of the preset pressure differential is reached and red LED at 100%.

Tightening Torque Values : Nm [ft/lbs] ±10%

Type	Inlet/Outlet Ports		Bowl to Head Torque	Mounting Holes	
	Size	Torque		Size	Torque
OFM20X 0020-0045	G 1-1/2"	175 [130]	40 [29]	M12 x 1.75	15 [11]
	SAE1-1/2"	-	40 [29]	M12 x 1.75	15 [11]

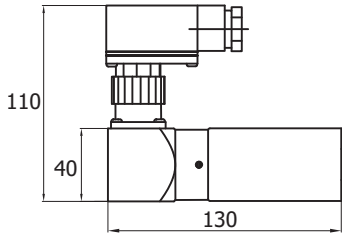

T = Optical/Electrical with 3 LEDs & 2 Switching points

Ordering Code
R-xx-GW-09-Z0-P

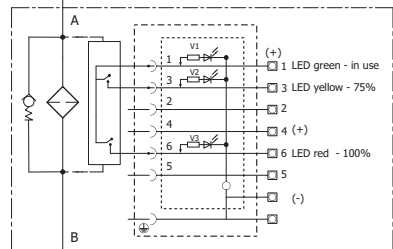

Dimensions

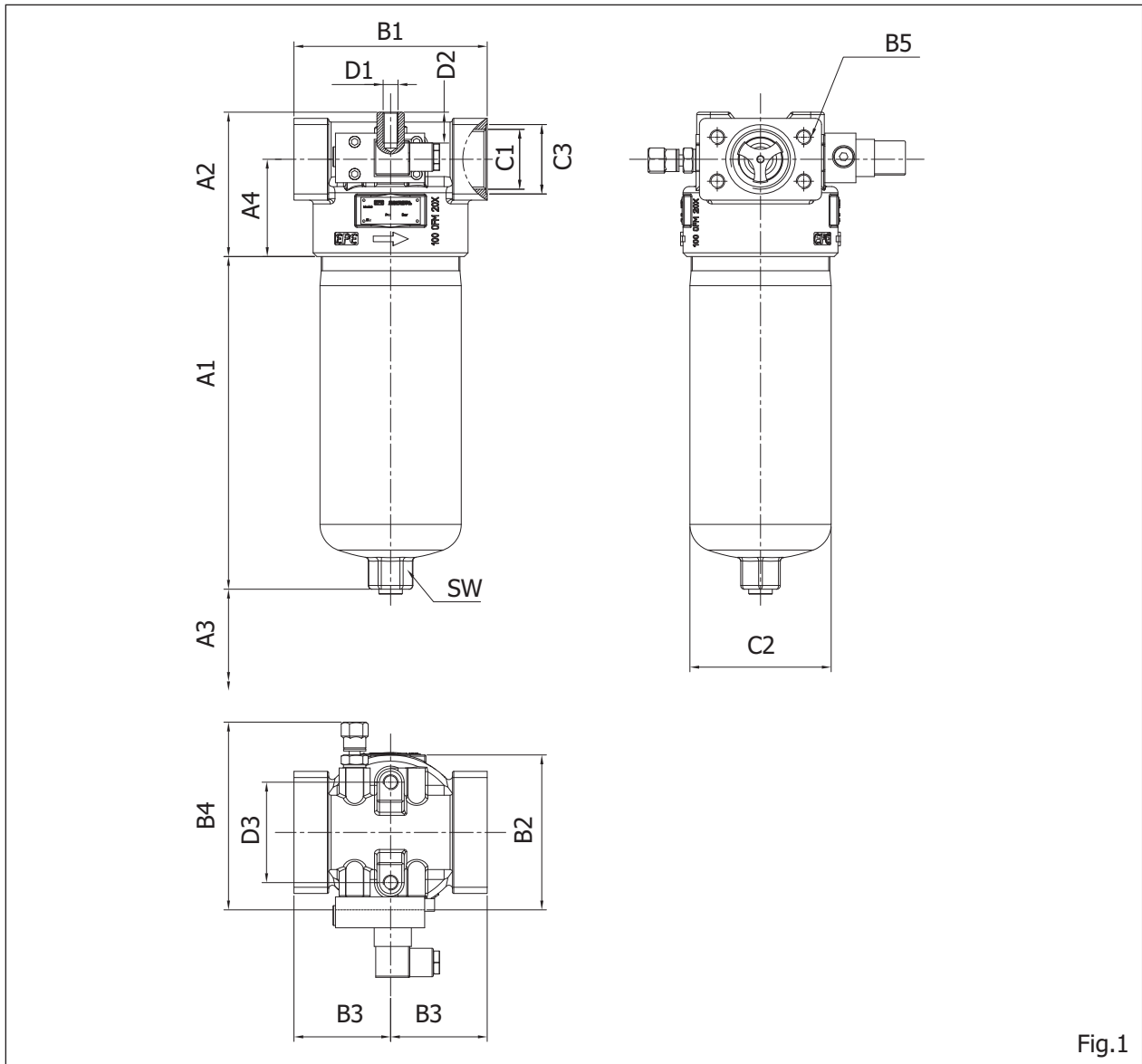

Fig.1

Type	Capacity ltr [gal]	Weight kg [lbs] ¹⁾	A1	A2	A3 ²⁾	A4	B1	B2	B3	B4
160 OFM20X 0020	1.3 [0.34]	12.5 [27.56]	178.5 [7.03]	116.5 [4.59]	160 [6.30]	78.5 [3.09]	156 [6.14]	125 [4.92]	78 [3.07]	151.5 [5.97]
160 OFM20X 0030	1.9 [0.50]	15.5 [34.17]	266.5 [10.49]		250 [9.84]					
160 OFM20X 0045	3.0 [0.79]	20.5 [45.19]	420.5 [16.56]		400 [15.75]					

Type	Connections B5, C1 & C3	C2	D1	D2	D3	SW
160 OFM20X 0020	R0 : G1-1/2" (C1) with Ø56x1dp (C3)	Ø114 [Ø4.49]	M12x1.75	25 [0.98]	81 [3.19]	32 [1.26]
160 OFM20X 0030	SOM : SAE 1-1/2" # 3000 with M12x1.75-25dp (B5)					
160 OFM20X 0045	SOU : SAE 1-1/2" # 3000 with 1/2"-13UNC-25dp (B5)					
	S24 : 1-7/8-12UN 2B - SAE J1926/1 (C1)					

¹⁾ = Weight including standard filter element and maintenance indicator

²⁾ = Servicing height for filter element replacement

Dimensions in mm [inch]

Spare parts list

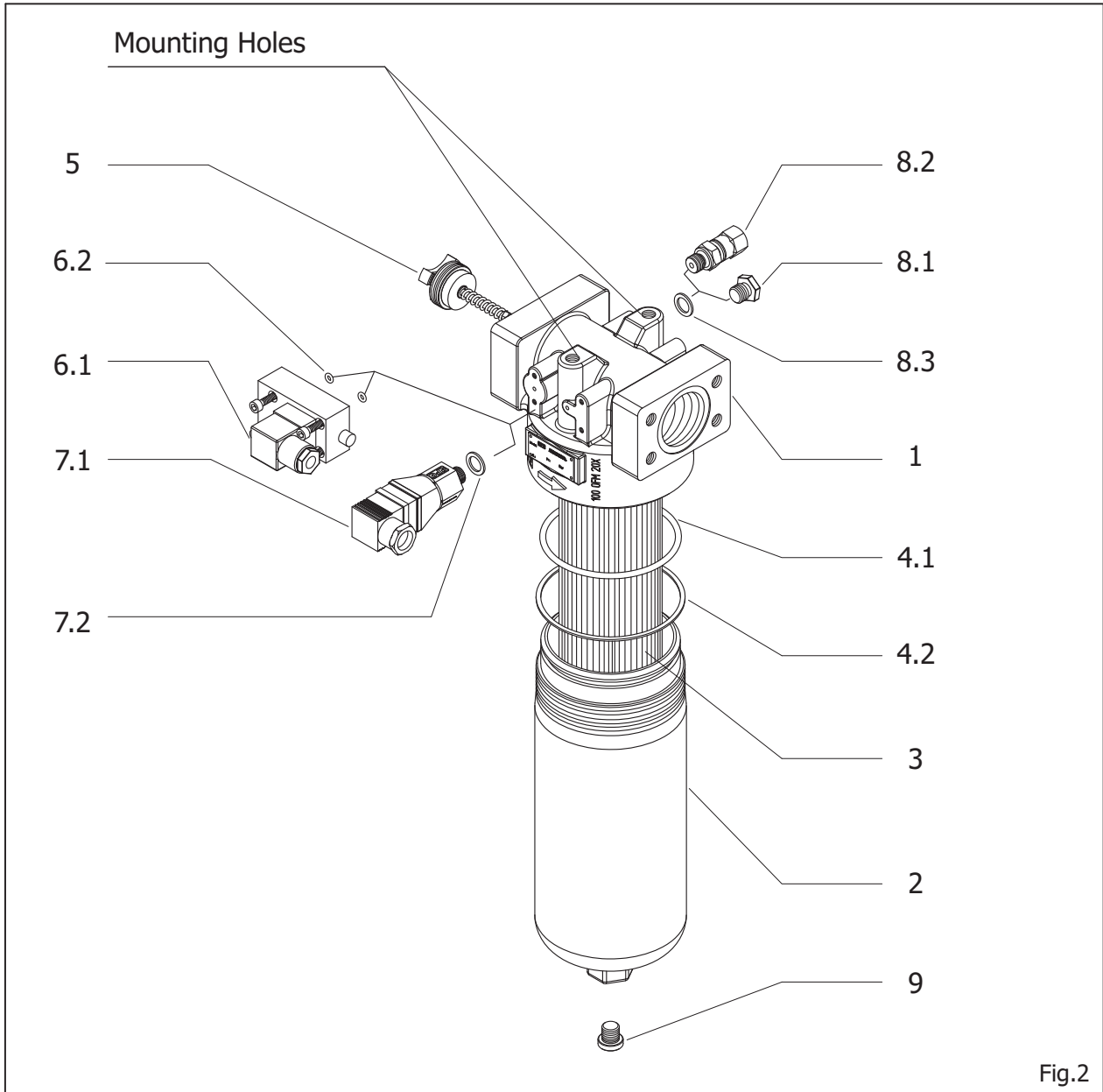

Fig.2

Spare Parts List

		Size OFM20X		0020	0030	0045
Item #	Qty.	Description	Material			
1	1	Filter Head	GGG40/GGG50		-	
2	1	Filter Bowl	Carbon steel		-	
3	1	Filter Element	Various	As per "Ordering Code - Filter Element"		
4.1	1	Housing O-Ring	Buna N/Viton	Sold as kit - "Ordering Code - Filter Seal Kit"		
4.2	1	Back-up Seal	Teflon	Sold as kit - "Ordering Code - Filter Seal Kit"		
5	1	Bypass Valve	Al / Synthetic	Part No.BYP03/xx		
6.1	1	DP Indicator	Aluminium	As per Section "Maintenance Indicator"		
6.2	2	DP Indicator O-Rings	Buna N/Viton	Sold as kit - "Ordering Code - Filter Seal Kit"		
7.1	1	Pressure Switch	Steel	As per Section "Maintenance Indicator"		
7.2	1	Seal Ring for Pre. Switch	Copper	Sold as kit - "Ordering Code - Filter Seal Kit"		
8.1	1	Air Vent Plug	Steel	Part No.AVP01		
8.2	1	Air Vent Valve	Various	Part No.AOO001		
8.3	1	Seal Ring for air vent	Copper	Sold as kit - "Ordering Code - Filter Seal Kit"		
9	1	Drain plug	Steel	Part No.DBP01		

xx - Cracking pressure (bar)

Installation

Before installation, conduct a visual check to ensure that the filter has not suffered any damage during shipping / handling. Verify that the requested type matches with what stamped on the nameplate.

Verify operating pressure with name plate information.

During assembly of the filter the tightening torques (refer page 4), the flow direction (direction arrows on the filter head) and the required service height (A3 in fig.1) of the filter element are to be taken into consideration.

Mount the filter assembly using the mounting holes on the filter head (D1) considering the flow direction. Failure to observe flow direction during assembly will cause damage to the filter element and components downstream.

Tighten the mounting bolts to specified torques (page 4).

We recommend using a suitable safety relief valve in the system to ensure the user and equipment are protected against possible damage caused by pressure surges.

Provide for the required servicing clearance below the filter for cleaning / replacing the filter element.

These filters must preferably be installed in vertical position with the filter bowl at the bottom to ensure proper venting and draining.

Proceed to the assembly ensuring the filter is not subjected to any abnormal forces and also fastened to avoid the transmission of vibrations. Tighten the inlet and outlet connections to the specified torques.

Make sure the optical part of the indicator is visible and the electricals connected appropriately.

If the maintenance indicator is ignored the bypass valve, if available, will open when the pressure differential increases thereby bypassing the filter element and contaminated fluid will pass to the clean side of the filter outlet thereby compromising the filtration effectiveness and risking the downstream components.

Connecting electrical indicator

Connect indicator using the three wired cable.

Verify electrical ratings on indicator (6.1 & 7.1) name plate.

Connection settings:

- | | |
|------------|----------------------------------|
| 1. Closer | 1 (black) + 3 (blue) |
| 2. Opener | 1 (black) + 2 (brown) |
| 3. Changer | 1 (black) + 2 (brown) + 3 (blue) |

Special Instructions

It is strictly forbidden to:

- weld or solder or carry out any mechanical operations on the filter.
- engrave or permanently stamp the surfaces of the filter and / or carry out other operations that could affect or change the mechanical properties of the filter.
- use the filter as a structural element: it should not be subjected to stresses or loads.
- change the data of the nameplate and / or filter without the permission of the manufacturer.
- use a different fluid than those designed for.

Starting Operation

Switch on the service pump.

Ensure the filter is completely filled with the working fluid and air in the housing vented through the vent plug (8.1) / vent valve (8.2).

Maintenance

The filter element is clogged and must be changed or cleaned when at operating temperature the red pointer on the pop-up indicator (6.1) is hard against the plastic cap / the pointer on the dual dial indicator (6.1) is at the end of the red marking and / or the switching process on the electrical indicator is triggered.

Filter element service

Switch off pump. Drain the filter housing through the drain plug (9) / drain valve. Unscrew filter bowl (2) and remove filter element (3), turning slightly off from its locator in the filter head (1). Check filter bowl inside and clean if necessary.

Filter element of type H...XL, H...XP, H...XE, H...XC, AS..., P... and VS ... is to be replaced.

Filter elements with G... & M... media are cleanable. The effectiveness of cleaning depends on the type of dirt and the level of the differential pressure at the time of changing the filter element. If the differential pressure after the filter element's cleaning process exceeds more than 50% of the pre-service value the G... & M... filter element also needs to be replaced.

Remove the safety packing from the new filter element before installing in the filter.

Replace filter element by slightly turning it back on its locator. Check Housing O-Ring (4.1) and Support Ring (4.2) on filter bowl (2), replace in case of damage or wear. Screw filter bowl and tighten to the specified torque (page 4) at hexagon bolt using a suitable tool.

Operate filter as described above.

Pressure Directives

Pressure Line Filters for hydraulic application are pressure holding equipment according to Article 2 Section 5 of the Pressure Equipment Directive 2014/68/EU. However, on the basis of the exception in Article 1, Section 2(f) of the PED the pressure line filters are exempt from the PED if they are not classified higher than category I (Guideline A-19) & do not receive any CE mark.

Disposal / Environmental Protection

Careless disposal of the filter, filter element and the residual fluid contained therein can cause environmental pollution.

Dispose the filter / filter element in accordance with provisions applicable in the country of use.

Fluid residues are to be disposed according to the respective safety data sheets valid for the specific hydraulic fluids.

Performance Curves (Flow rate Vs Pressure Drop) - for complete filters

Oil Viscosity : 30 mm²/s [143 SUS]

Specific gravity < 0.9 kg/dm³

Recommended initial Pressure Drop (ΔP) for assembly = 0.8 bar [11.6 psid]

